

GENERAL INFORMATION

Air Bag Deactivation Procedures - Hummer

SPECIAL CARE DURING MECHANICAL REPAIRS

WARNING: To avoid injury from accidental air bag deployment, read and carefully follow all **SERVICE PRECAUTIONS** and **DISABLING & ACTIVATING AIR BAG SYSTEM** procedures.

WARNING: In an effort to create safer air bags, manufacturers are using dual stage inflator modules with 2 deployment stages. Some models use 2 stage deployment inflators on driver and passenger air bag modules. If stage one was used to deploy a dual stage inflator module, stage 2 may still be active. Therefore, a deployed 2 stage air bag inflator module must be treated as an active module. When deactivating an air bag system with deployed air bags, a deployed 2 stage air bag may still be active. If disposal of a deployed or undeployed dual stage module is required, both deployment loops must be energized to deploy the air bag.

In some instances, it may be necessary to remove the steering column or instrument panel to access electrical components. Observe specific manufacturer SERVICE PRECAUTIONS when working on a vehicle with an air bag system.

Electrical power sources should NEVER be allowed to contact the inflator on the back of the air bag module. NEVER probe air bag system electrical wires with an analog volt-ohmmeter or test light. Always disable air bag system before servicing vehicle. See appropriate DISABLING & ACTIVATING AIR BAG SYSTEM procedure. Failure to disable system properly may result in accidental air bag deployment and possible personal injury.

If air bag system is not fully functional for any reason, DO NOT drive vehicle until system is repaired and functions properly. DO NOT remove bulbs, modules, sensors, or other air bag components which will prevent air bag system from operating as designed. If air bag system is not functional, park vehicle until system is repaired and functions properly.

SYSTEM OPERATION CHECK

WARNING: Use caution while reaching in and turning ignition switch to ON position.

H2 WITH PASSENGER AIR BAG

Turn ignition switch from OFF to ON or RUN position. AIR BAG warning light should flash 7 times and then turn off.

The following AIR BAG warning light conditions indicate possible SIR system faults:

- Light does not illuminate at all.
- Light remains illuminated when ignition is turned on.
- Light illuminates while vehicle is driven.

SIR system faults are usually due to a disconnected/loose electrical connector caused by previous service on vehicle. Always check all Yellow SIR connectors for loose connections or damage.

If all connectors are okay, and AIR BAG warning light is still not operating properly, diagnose SIR system. Repair air bag system as necessary.

H2 WITH PASSENGER PRESENCE SYSTEM

PASSENGER AIR BAG ON/OFF indicators located on the rear view mirror are used to notify the driver when the Passenger Presence System (PPS) has enabled or disabled the instrument panel inflator module. The PPS air bag indicators will also inform the driver of any PPS malfunctions. When the ignition is turned on, the PPS module is supplied with ignition 1 voltage and commands both PASSENGER AIR BAG ON/OFF indicators ON for 5 seconds. The PPS module conducts tests on the PPS components and circuits while both ON/OFF indicators are ON. If no malfunctions are detected, the PPS module will turn the PASSENGER AIR BAG indicator ON or OFF depending on the status of the PPS. If a malfunction is detected, the PPS module will store a Diagnostic Trouble Code (DTC), default the PPS to the OFF state and communicate with the SDM that a DTC has been set. When the SDM detects that the PPS has set a DTC, the SDM will set either DTC B0092 or B0098 and request the Instrument Panel Cluster (IPC) to turn the AIR BAG indicator located on the IPC ON. This is done to notify the driver of any PPS malfunctions. The presence of a SIR system malfunction could result in non-deployment of the air bags. The AIR BAG indicator will remain ON until the malfunction has been repaired.

NOTE: **When the following conditions apply:**

- **Air Bag lamp is on.**
- **Passenger Air Bag indicator always reads off.**
- **DTC B0092 is reported.**

The cause of this condition may be a shorted Passenger Presence System (PPS) sensor wire. The PPS sensor harness is located under the front passenger seat. This harness may be pinched between the seat frame and the track/riser.

SERVICE PRECAUTIONS

Observe the following service precautions when working with air bag systems:

- Disable appropriate air bag system zone or zones before servicing any air bag system or steering column component. Failure to do this may result in accidental air bag deployment and possible personal injury.

See **DISABLING & ACTIVATING AIR BAG SYSTEM**.

- Sensing and Diagnostic Module (SDM) maintains a reserve energy supply. Deployment power is available for as long as one minute after disconnecting battery power. Servicing vehicle before this time limit is reached may cause accidental air bag deployment and possible personal injury.
- After repairs, stay well away from air bag inflator module(s), and turn ignition switch to ON position. Ensure AIR BAG warning light is working properly and no system faults are indicated. See **SYSTEM OPERATION CHECK**.
- Use only new, original equipment replacement parts. DO NOT use salvaged parts for SIR system repairs.
- DO NOT expose air bag inflator modules to temperatures above 150°F (65°C).
- Always wear safety glasses when servicing or handling an air bag.
- Air bag module must be stored in its original special container until it is ready to be used for service. It must be stored in a clean, dry place, away from sources of extreme heat, sparks or high electrical energy.
- When placing a live air bag module on a bench or other surface, always face air bag and trim cover upward, away from surface. This will reduce motion of module if it is accidentally deployed.
- After deployment, air bag surface may contain deposits of sodium hydroxide which can irritate skin. Always wear safety glasses, rubber gloves and a long-sleeved shirt during clean-up. Wash hands using mild soap and water. Follow correct disposal procedures.
- When carrying a live air bag module, point trim cover away from your body to minimize injury in case of accidental deployment. DO NOT carry live air bag module by wiring harness or connector.
- DO NOT carry seat belt pretensioner by wiring harness or connector. Seat belt pretensioner can be carried by piston tube. When handling a live seat belt pretensioner, DO NOT touch seat belt pretensioner in cable area between buckle and mounting bolt hole. DO NOT cover pretensioner piston tube opening with hands or point open end at yourself or others.
- Coil assembly must be replaced whenever air bag is deployed. Replace SDM, driver air bag module, passenger air bag module, side air bag module, side air bag sensor or front air bag sensor if any component has been dropped from a height of 3 feet or more.
- DO NOT attempt to repair SDM, air bag inflator modules, air bag sensors or steering wheel coil assembly. Service all components by replacement only.
- Electrical sources should never be allowed near inflator on back of air bag module.
- Avoid touching SDM terminals to prevent electrostatic discharge damage.
- If water enters the vehicle's interior and soaks the carpet up to level of SDM, inspect the affected area and remove all evidence of water. Repair water damage, replace SDM, and replace harness connector. Failure to do this may result in accidental air bag deployment and possible personal injury.
- If air bag system is not fully functional for any reason, vehicle should not be driven until system is repaired. DO NOT remove bulbs, modules, sensors or other components, or in any way disable system from operating normally. If air bag system is not functional, park vehicle until repairs can be made.

DISABLING & ACTIVATING AIR BAG SYSTEM

WARNING: Sensing and Diagnostic Module (SDM) maintains a reserve energy supply. Deployment power is available for as long as one minute after disconnecting battery power. Servicing vehicle before this time limit is

reached may cause accidental air bag deployment and possible personal injury.

NOTE: When AIR BAG or SIR fuse is removed, and ignition is in ON position, AIR BAG warning light will illuminate. This is normal operation and does not indicate SIR system malfunction.

SUPPLEMENTAL INFLATABLE RESTRAINT DISABLING & ENABLING ZONES

NOTE: Not all zones are used by all vehicles.

The Supplemental Inflatable Restraint (SIR) system has been divided into disabling and enabling zones. When performing service on or near SIR components or SIR wiring, it may be necessary to disable the SIR components in that zone. It may be necessary to disable more than one zone depending on the location of other SIR components and the area being serviced. See **Fig. 1**. Identify the specific zone or zones in which service will be performed and disable and enable selected zone or zones.

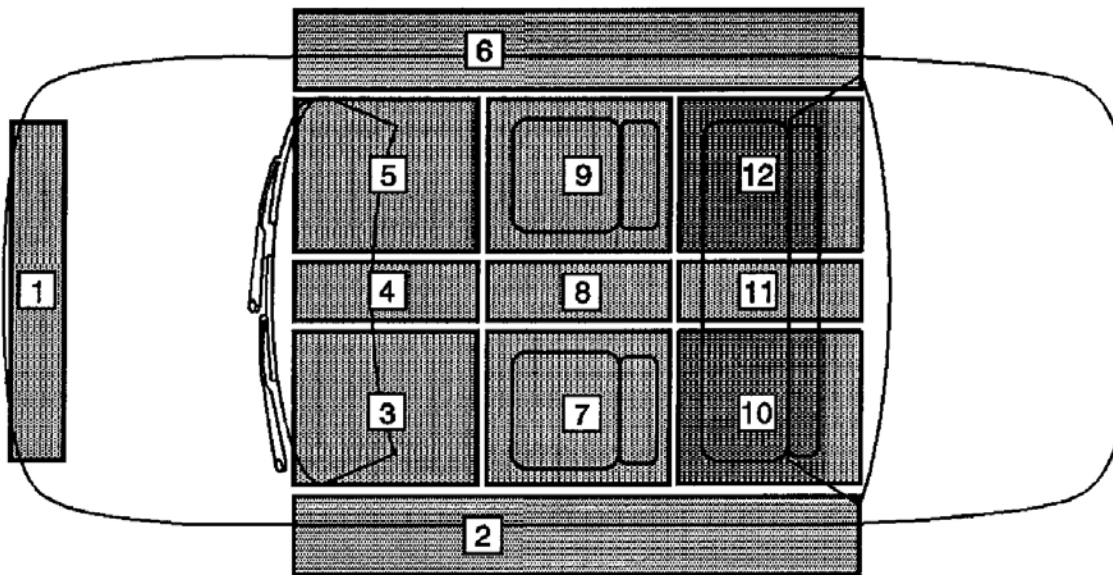

G00077838

Fig. 1: Locating Supplemental Inflatable Restraint (SIR) Disabling & Enabling Zones (Typical)
Courtesy of GENERAL MOTORS CORP.

H2

NOTE: With the SIR fuse removed and the ignition ON, the AIR BAG indicator illuminates. This is normal operation and does not indicate an SIR system malfunction.

Disabling System

1. Before proceeding, follow air bag service precautions. See **SERVICE PRECAUTIONS**. Ensure front

wheels are in straight-ahead position. Remove key. Remove AIR BAG fuse from the underhood fuse block.

Zone 1 - Remove the Connector Position Assurance (CPA) clip from both Electronic Frontal Sensor (EFS) connectors located on the frame crossmember. Disconnect the EFS connectors.

Zone 3 - Remove the CPA from the steering wheel module Yellow 2-pin connector located left of the steering column near the knee bolster. Disconnect the steering wheel module yellow 2-pin connector. See **Fig. 2** .

Zone 5 - Remove the CPA clip from the (1) I/P module yellow 2-way connector (2) located behind the I/P module. Disconnect the (1) I/P module yellow 2-way connector (2) located behind the I/P module. See **Fig. 3** .

Zone 7 - To disable inflatable restraint Sensing and Diagnostic Module (SDM) located in SIR Zone 7, disable Zones 3 and 5. Remove CPA clip from components Yellow connector. Disconnect components Yellow connector from vehicle harness Yellow connectors.

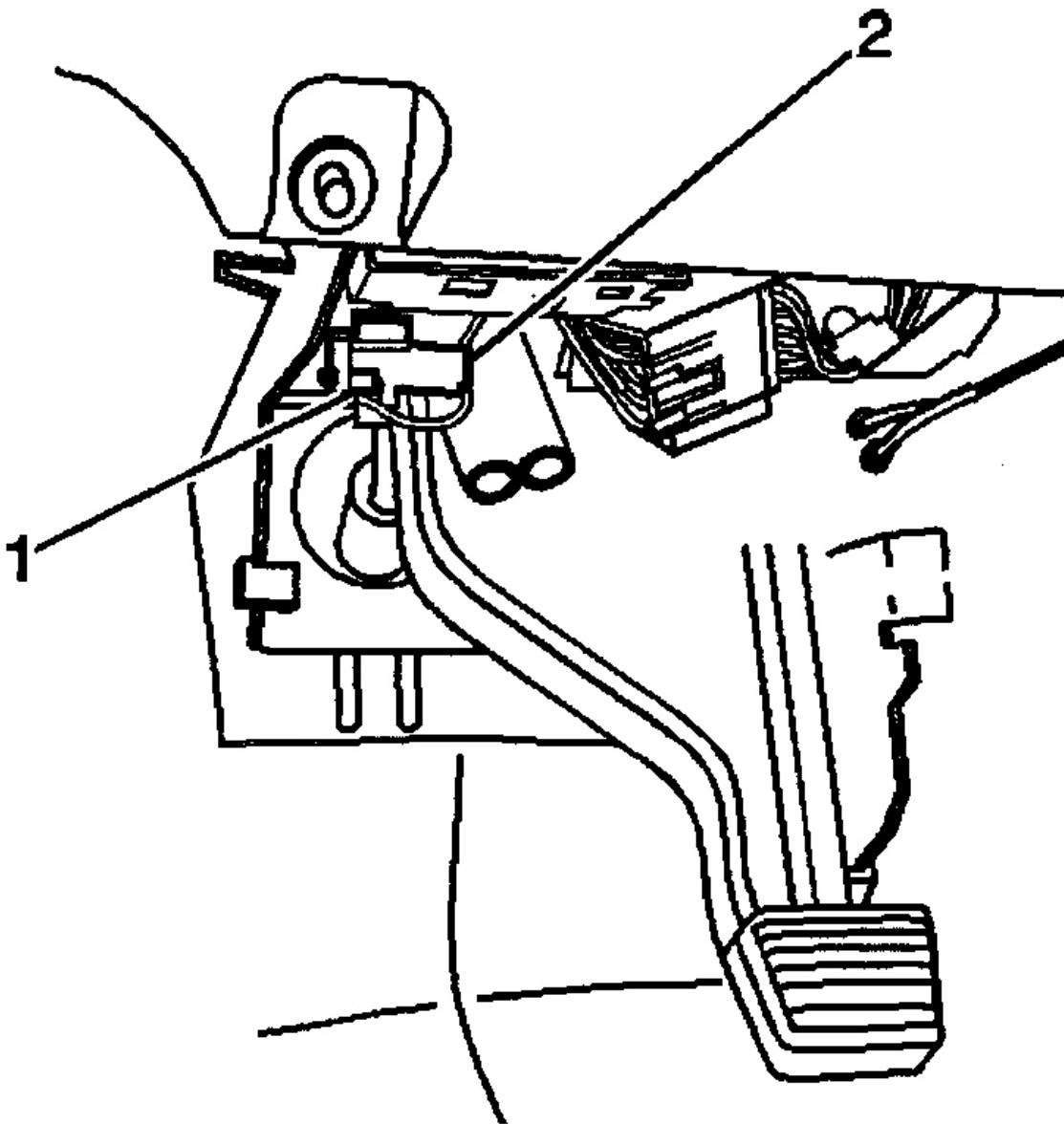

1. Connector Position Assurance (CPA)
2. Driver Air Bag Yellow 4-Pin Connector

G00077842

Fig. 2: Locating Driver Air Bag Yellow 4-Pin Connector
Courtesy of GENERAL MOTORS CORP.

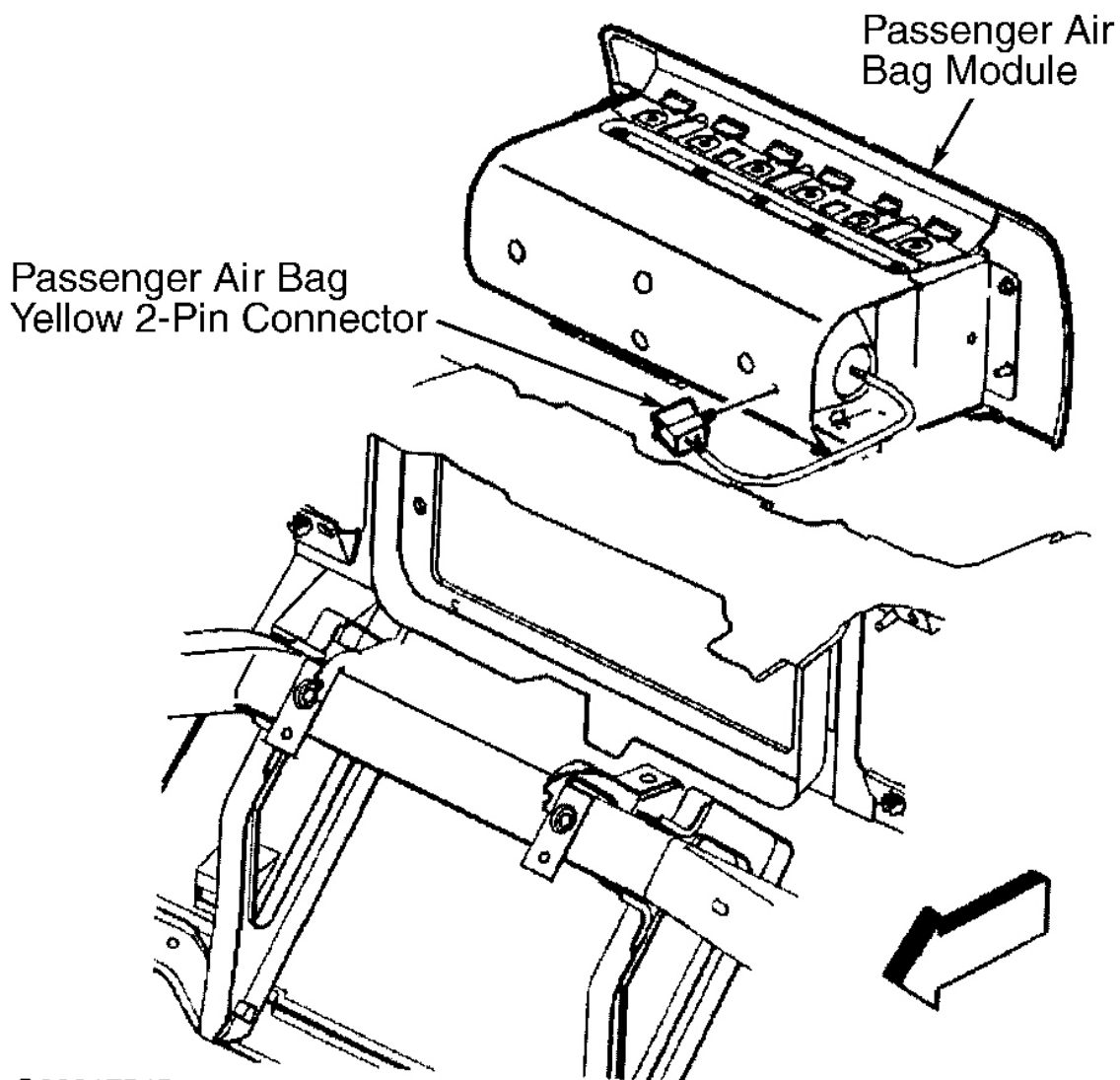

G00017545

Fig. 3: Locating Passenger Air Bag Yellow 2-Pin Connector
Courtesy of GENERAL MOTORS CORP.

Activating System

Remove key from ignition switch. Ensure SDM fuse is still removed from fuse block. In reverse order, connect SIR component Yellow SIR connectors to vehicle harness and install CPA clips. Install SIR fuse in fuse block. Staying away from air bags, turn ignition switch to ON position. Ensure AIR BAG warning light flashes 7 times, and then turns off. To complete installation, reverse removal procedures.

2004 RESTRAINTS

SIR - Hummer H2

SPECIFICATIONS

FASTENER TIGHTENING SPECIFICATIONS

Fastener Tightening Specifications

Application	Specification	
	Metric	English
Inflatable Restraint Front End Sensor	10 N.m	89 lb in
Inflatable Restraint Instrument Panel Module	10 N.m	89 lb in
Inflatable Restraint (SD) Module	10 N.m	89 lb in

SCHEMATIC AND ROUTING DIAGRAMS

SIR SCHEMATIC ICONS

SIR Schematic Icons

Icon	Icon Definition
	<p>CAUTION: When performing service on or near the SIR components or the SIR wiring, the SIR system must be disabled. Refer to SIR Disabling and Enabling Zones. Failure to observe the correct procedure could cause deployment of the SIR components, personal injury, or unnecessary SIR system repairs.</p>
	<p>IMPORTANT: In order to prevent accidental deployment, the shorting bars close in order to short the connectors when the connectors are separated.</p>



SIR SCHEMATICS

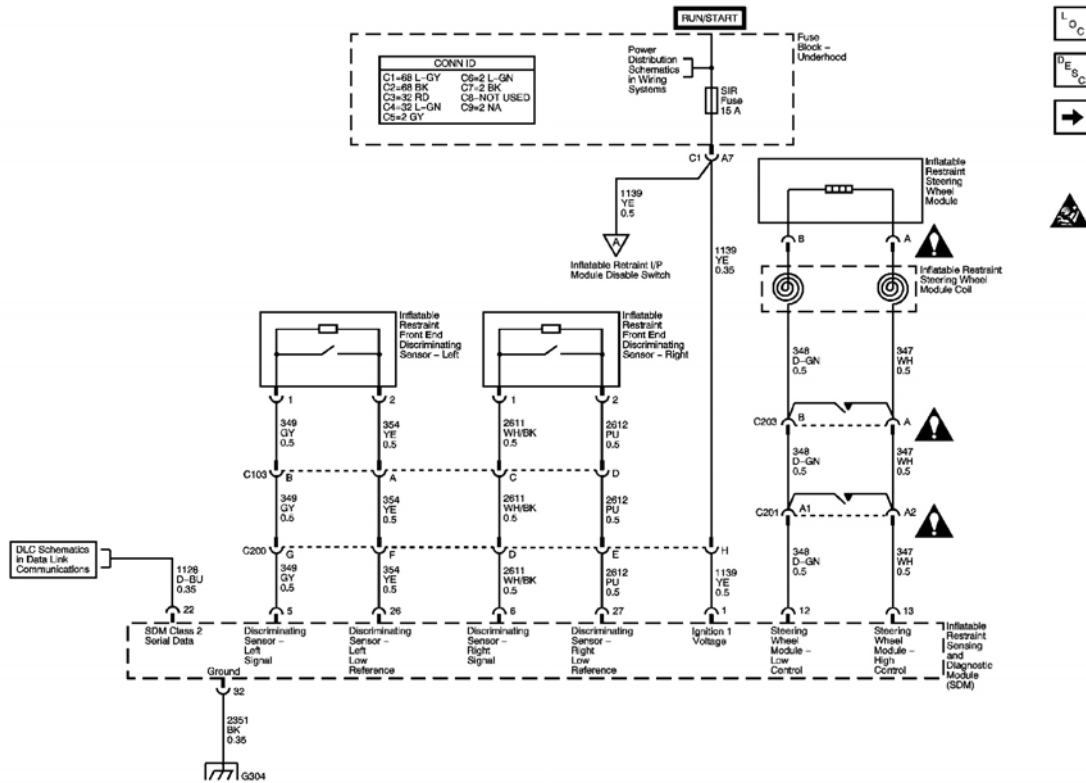

Fig. 1: SDM Power, Grounding, DLC, Sensors, and Driver Air Bag Schematic
 Courtesy of GENERAL MOTORS CORP.

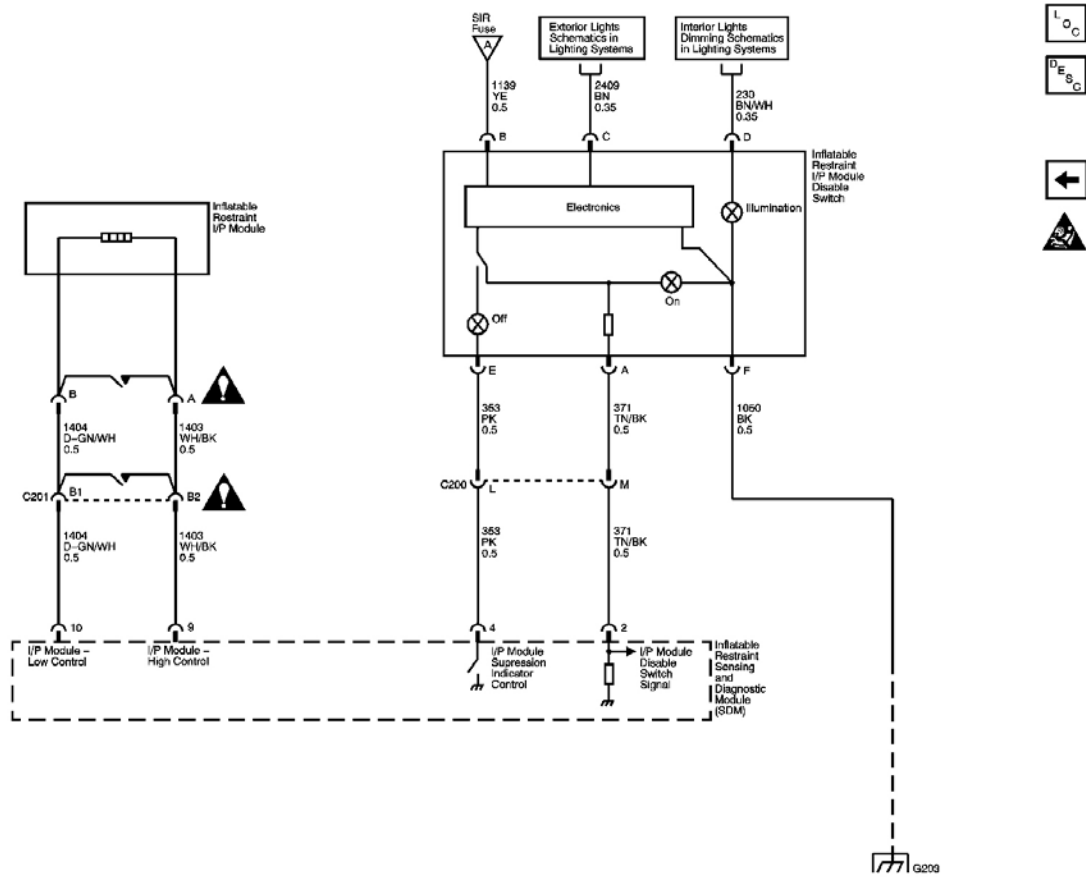

Fig. 2: Passenger Air Bag and Defeat Switch Schematic
 Courtesy of GENERAL MOTORS CORP.

COMPONENT LOCATOR

SIR COMPONENT VIEWS

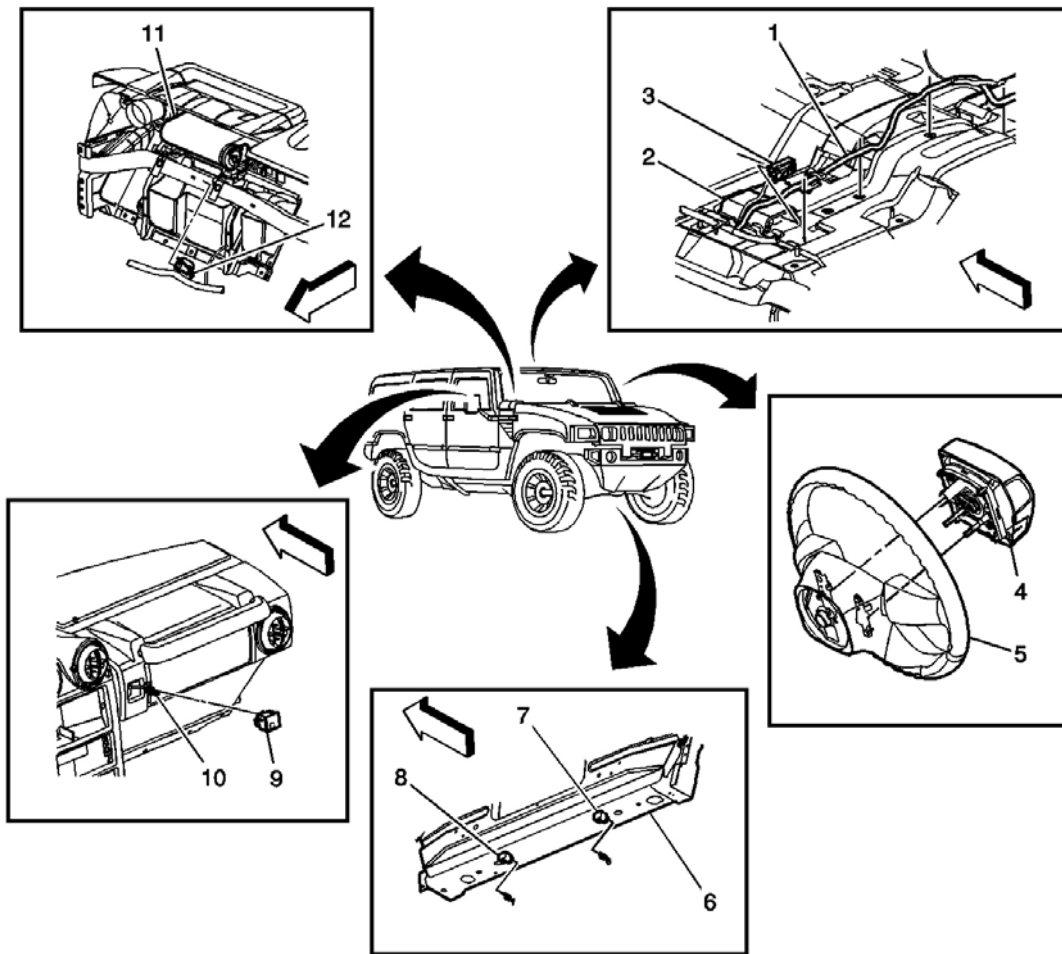

Fig. 3: SIR Sub-System Component Views
 Courtesy of GENERAL MOTORS CORP.

Callouts For Fig. 3

Callout	Component Name
1	Body Harness
2	Inflation Restraint Sensing and Diagnostic Module (SDM)
3	Inflation Restraint Sensing and Diagnostic Module (SDM) Connector
4	Inflation Restraint Steering Wheel Module
5	Steering Wheel
6	Radiator Support
7	Inflation Restraint Front End Discriminating Sensor - Left
8	Inflation Restraint Front End Discriminating Sensor - Right
9	Inflation Restraint I/P Module Disable Switch
10	Inflation Restraint I/P Module Disable Switch Connector

11	Inflatable Restraint I/P Module
12	Inflatable Restraint I/P Module Connector

SIR ZONE IDENTIFICATION VIEWS

The SIR Zone Identification Views shown below illustrate the approximate location of all SIR components available for the vehicle. This will assist in determining the appropriate SIR Disabling and Enabling Zones for a given service procedure, refer to **SIR Disabling and Enabling Zones** .

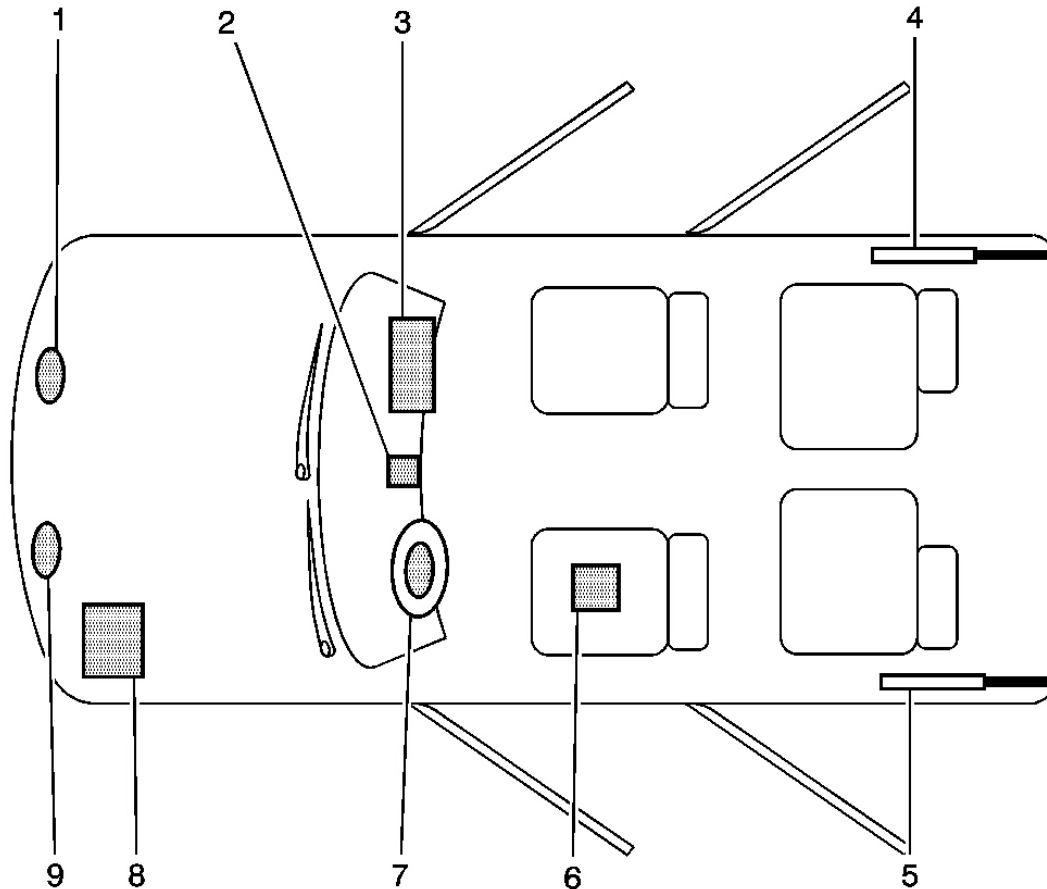

Fig. 4: Hummer H2 SIR Zone Identification Views
 Courtesy of GENERAL MOTORS CORP.

Callouts For Fig. 4

Callout	Component Name
1	Inflatable Restraint Electronic Frontal Sensor (EFS) - Located on the front of the vehicle in the engine compartment
	Inflatable Restraint I/P Module Disable Switch - Located at the top right under the instrument

2	panel
3	Inflatable Restraint I/P Module - Located at the top right under the instrument panel
4	Rear Lift Gate Strut - A gas shock is located between rear lift gate and body on the passenger side
5	Rear Lift Gate Strut - A gas shock is located between rear lift gate and body on the driver side
6	Inflatable Restraint Sensing and Diagnostic Module (SDM) - Located underneath the LF/driver seat
7	Inflatable Restraint Steering Wheel Module - Located on the steering wheel
8	Battery - Located under Hood on the left side
9	Inflatable Restraint Electronic Frontal Sensor (EFS) - Located on the front of the vehicle in the engine compartment

SIR CONNECTOR END VIEWS

Inflatable Restraint Front End Discriminating Sensor Terminal Identification - Left

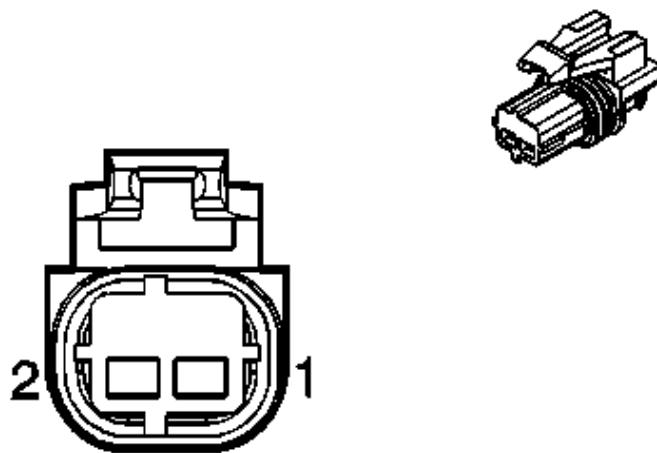

Connector Part Information		<ul style="list-style-type: none"> • 15356718 • 2-Way F GT 150 Sealed 4.0 (YE) 	
Pin	Wire Color	Circuit No.	Function
1	GY	349	Discriminating Sensor - Left - Signal
2	YE	354	Discriminating Sensor - Left-Low Reference

Inflatable Restraint Front End Discriminating Sensor Terminal Identification - Right

--	--	--	--

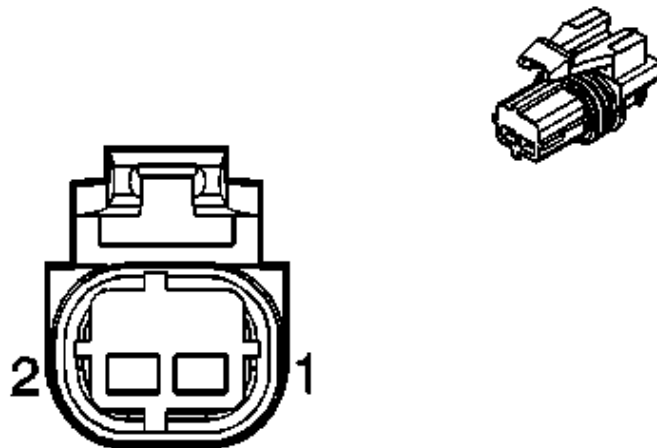

Connector Part Information		<ul style="list-style-type: none"> • 15356718 • 2-Way F GT 150 Sealed 4.0 (YE) 	
Pin	Wire Color	Circuit No.	Function
1	WH/BK	2611	Discriminating Sensor - Right - Signal
2	PU	2612	Discriminating Sensor - Right - Low Reference

Inflatable Restraint I/P Module Disable Switch Terminal Identification

--	--

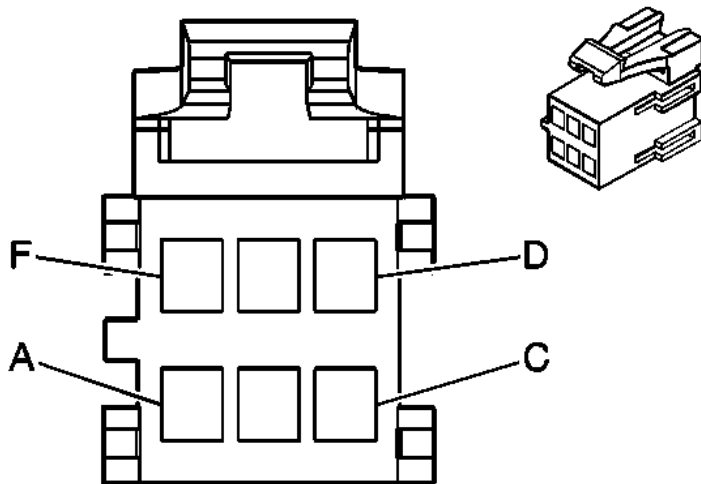

Connector Part Information		<ul style="list-style-type: none"> • 15305286 • 6-Way F Metri-Pack 150 Series (YE) 	
Pin	Wire Color	Circuit No.	Function
A	TN/BK	371	I/P Module Disable Switch - Signal
B	YE	1139	Ignition 1 Voltage
C	BN	2409	Interior Park Lamps Supply Voltage
D	BN/WH	230	Instrument Panel Lamps Dimming Control
E	PK	353	I/P Module Suppression Indicator Control
F	BK	1050	Ground

Inflatable Restraint I/P Module Terminal Identification

--	--

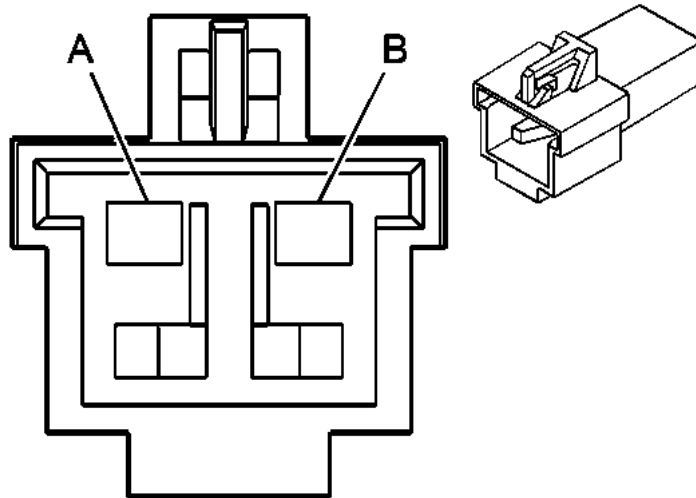

Connector Part Information		<ul style="list-style-type: none"> • 12186989 • 2-Way M Metri-Pack 280 Pull To Seat (YE) 	
Pin	Wire Color	Circuit No.	Function
A	WH/BK	1403	I/P Module - High Control
B	D-GN/ WH	1404	I/P Module - Low Control

Inflatable Restraint Sensing and Diagnostic Module (SDM) Terminal Identification

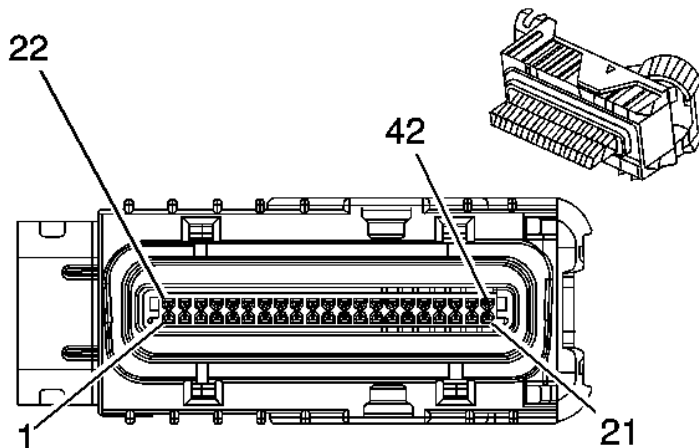

Connector Part Information

- 15356922
- 42-Way F Micro-Pack 100 W (YE)

Pin	Wire Color	Circuit No.	Function
1	YE	1139	Ignition 1 Voltage
2	TN/BK	371	I/P Module Disable Switch - Signal
3	BK/WH	238	Seat Belt Switch - Left
4	PK	353	I/P Module Suppression Indicator Control
5	GY	349	Discriminating Sensor - Left - Signal
6	WH/BK	2611	Discriminating Sensor - Right - Signal
7-8	-	-	Not Used
9	WH/BK	1403	I/P Module - High Control
10	D-GN/ WH	1404	I/P Module - Low Control
11	D-BU	1363	Seat Belt Switch - Left-Low Reference
12	D-GN	348	Steering Wheel Module - Low Control
13	WH	347	Steering Wheel Module - High Control
14-21	-	-	Not Used
22	D-BU	1128	SDM Class 2 Serial Data
23-25	-	-	Not Used
26	YE	354	Discriminating Sensor - Left-Low Reference
27	PU	2612	Discriminating Sensor - Right-Low Reference
28-31	-	-	Not Used
32	BK	2351	Ground
33-42	-	-	Not Used

Inflatable Restraint Steering Wheel Module Terminal Identification

--

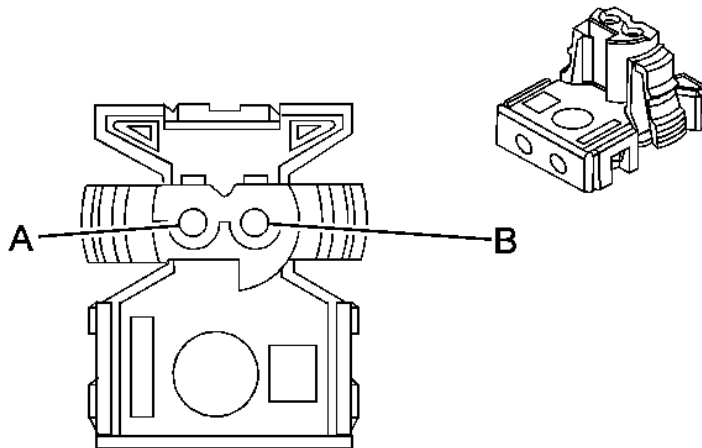

Connector Part Information		<ul style="list-style-type: none"> • 54560210 • 2-Way F Framatone ABX-3 Code C (YE) 	
Pin	Wire Color	Circuit No.	Function
A	WH	347	Steering Wheel Module - High Control
B	D-GN	348	Steering Wheel Module - Low Control

DIAGNOSTIC INFORMATION AND PROCEDURES

DIAGNOSTIC STARTING POINT - SIR

Begin the system diagnosis with **Diagnostic System Check - SIR**. The Diagnostic System Check - SIR will provide the following information:

- The identification of the control module(s) which commands the system.
- The ability of the control module(s) to communicate through the serial data circuit.
- The identification of any stored diagnostic trouble codes (DTCs) and their status.

The use of **Diagnostic System Check - SIR** will identify the correct procedure for diagnosing the system and where the procedure is located.

DIAGNOSTIC SYSTEM CHECK - SIR

CAUTION: Refer to **SIR Special Tool Caution in Cautions and Notices**.

These diagnostic procedures will help you to find and repair SIR system malfunctions. This service category

also contains information for repairing SIR system malfunctions. For best results, use the diagnostic tables, and follow the sequence listed below:

1. Perform the Diagnostic System Check - SIR. All SIR diagnostics must begin with the A Diagnostic System Check - SIR. The Diagnostic System Check - SIR determines the following results:
 - Proper AIR BAG warning lamp operation
 - Ability of the SDM to communicate through the data link connector (DLC)
 - Existence of SIR current and/or history diagnostic trouble codes (DTC)
2. Refer to the diagnostic table as directed by the A Diagnostic System Check - SIR. The diagnostic tables will help enable you to diagnose any SIR system malfunction. Bypassing these procedures may result in the following problems:
 - Extended diagnostic time
 - Incorrect diagnosis
 - Incorrect parts replacement
3. Repeat the Diagnostic System Check - SIR after you perform any repairs or diagnostic procedures. This will verify that you correctly performed the repair. This will also ensure that no other malfunctions exist.

Test Description

The numbers below refer to the step numbers on the diagnostic table.

1: This step checks to see if the AIR BAG warning lamp flashes seven times and then turns off when the ignition key is turned ON.

2: This step checks to see if the scan tool powers up.

3: This step checks to see if the scan tool can communicate with the inflatable restraint sensing and diagnostic module (SDM).

4: This step checks to see if there are any current or history diagnostic trouble codes (DTCs) present.

5: This step checks to see if there are communication DTCs (U-codes) present.

6: This step checks to see if DTC B1000 (ECU Malfunction) is present.

Diagnostic System Check - SIR

Step	Action	Yes	No
1	1. Note the AIR BAG warning lamp while turning the ignition switch ON. 2. The AIR BAG warning lamp should turn OFF after flashing seven times. Does the AIR BAG warning lamp flash seven times and then turn off?	Go to Step 2	Go to Symptoms - SIR

2	Install a scan tool. Does the scan tool power up?	Go to Step 3	Go to <u>Scan Tool Does Not Power Up</u> in Data Link Communications
3	Attempt to establish communication with the inflatable restraint sensing and diagnostic module (SDM). Does the scan tool communicate with the SDM?	Go to Step 4	Go to <u>Scan Tool Does Not Communicate with Class 2 Device</u> in Data Link Communications
4	<ol style="list-style-type: none"> 1. Use the scan tool to request the SIR diagnostic trouble code (DTC) display. 2. Record the displayed DTC (s) on the repair order, specifying as current or history. Does the scan tool display any current or history DTCs?	Go to Step 5	System OK
5	Does the scan tool display any DTC's which begin with a "U"?	Go to <u>Scan Tool Does Not Communicate with Class 2 Device</u> in Data Link Communications	Go to Step 6
6	Does the scan tool display DTC B1000?	Go to <u>DTC B1000</u> in Body Control System	Go to <u>Diagnostic Trouble Code (DTC) List</u>

SCAN TOOL DATA LIST

The SIR Scan Tool Data List contains all the restraint system related parameters that are available on the scan tool. The parameters in the list are arranged in alphabetical order. The column, "Data List," indicates the location of the parameter within the scan tool menu selections.

Use the SIR Scan Tool Data List as directed by a diagnostic table or in order to supplement the diagnostic procedures. Begin all of the diagnostic procedures with the SIR Diagnostic System Check. Use the SIR Scan Tool Data List after the following are determined:

- There is no published DTC procedure nor published symptom procedure for the customer concern.
- The DTC or symptom diagnostic procedure indicated by the diagnostic system check does not resolve the customer concern.

The Typical Data Values are obtained from a properly operating vehicle under the conditions specified in the first row of the Scan Tool Data List table. Comparison of the parameter values from the suspect vehicle with the Typical Data Values may reveal the source of the customer concern.

SIR Scan Tool Data List

Scan Tool Parameter	Data List	Units Displayed	Typical Data Value
Ignition ON/Engine OFF/Driver Seat Belt Buckled/Active Switch Enabled			
8-Digit GM Part Number	Module Information 2	8-digit number	XXXXXXXX
Active Switch	Inputs	Enabled/Disabled	Enabled
Calibration ID	Module Information 1	4-digit number	Varies
Component Serial Number	Module Information 2	4-digit number	XXXX
Driver Side Belt Status	Inputs	Buckled/Unbuckled	Buckled
Electronic Front End Sensor 1 ID	Module Information 1	2-digit number	Varies
Electronic Front End Sensor 2 ID	Module Information 1	2-digit number	Varies
Ignition Voltage	Data	Volts	12 volts
Julian Date of Build	Module Information 1	3-digit number	Varies
ROM ID	Module Information 1	4-digit number	Varies
Year Module Built	Module Information 1	4-digit number	Varies

SCAN TOOL DATA DEFINITIONS

The SIR scan tool data definitions contain a brief description of all SIR related parameters available on the scan tool. The parameters that are available on the scan tool are listed below in alphabetical order.

8 Digit GM Part Number

The scan tool displays an 8 digit part number. This number is the GM part number that is stored within the SDM memory.

Active Switch

The scan tool displays enabled or disabled. The signal from the inflatable restraints I/P module disable switch indicates whether the passenger frontal air bag is enabled or disabled.

Calibration ID

The scan tool displays a 4 digit number. This calibration ID is the check sum of the SDM read only memory contents.

Component Serial Number

The scan tool displays the digits of the SDM serial number.

Driver Side Belt Status

The scan tool displays Buckled or Unbuckled. The signal from the drivers seat belt switch indicates whether the driver seat is buckled or unbuckled.

Electronic Front End Sensor ID

The scan tool displays a 2 digit ID number. The ID signal is sent to the SDM from the front end sensor.

Ignition Voltage

The scan tool displays 0-20 volts. The Ignition represents the system voltage measured by the SDM at its ignition feed.

Julian Date of Build

The scan tool displays a 3 digit number. Which represents the day of the year the module was built.

ROM ID

The scan tool displays a 4 digit number. This number is the programmable read-only memory (PROM) ID.

Year Module Built

The scan tool displays what year the module was built.

DIAGNOSTIC TROUBLE CODE (DTC) LIST

Diagnostic Trouble Code (DTC) List

DTC	Description	Module
B0016, B0017, or B0018	<u>DTC B0016, B0017, or B0018</u>	SDM
B0022, B0024, or B0026	<u>DTC B0022, B0024, or B0026</u>	SDM
B0051	<u>DTC B0051</u>	SDM
B0053	<u>DTC B0053</u>	SDM
B0090	<u>DTC B0090</u>	SDM
B0091	<u>DTC B0091</u>	SDM
B0100, B0101, B0102, B0103, B0104, or B0105	<u>DTC B0100, B0101, B0102, B0103, B0104, or B0105</u>	SDM
B1001	<u>DTC B1001</u>	SDM
U1001 - U1254	<u>DTC U1001-U1254</u> in Data Link Communications	EBCM, Passlock Module, PCM, SDM, VIM
U1300 and U1301	<u>DTC U1300, U1301, or U1305</u> in Data Link Communications	EBCM, Passlock Module, PCM, SDM, VIM

DTC B0016, B0017, OR B0018

Circuit Description

The passenger deployment loop consists of a inflatable restraint I/P module, the I/P module high and I/P module

low circuits. There is a shorting bar used within the I/P module connector which will short together both I/P module high and low circuits when the connector is disconnected, this will help to prevent unwanted deployment of the inflator module during servicing. During a frontal crash of sufficient force the inflatable restraint sensing and diagnostic module (SDM) will allow current to flow through the deployment loop in order to deploy the I/P module. The SDM performs continuous diagnostic tests on the deployment loops to check for proper circuit continuity and for shorts to ground or voltage. If a malfunction is detected, a diagnostic trouble code (DTC) will be stored in memory.

Conditions for Running the DTC

Ignition 1 voltage is within the normal operating voltage range.

Conditions for Setting the DTC

- DTC B0016 will set when the I/P module deployment loop resistance is less than 1.3 ohms for 500 milliseconds.
- DTC B0017 will set when one of the following conditions occurs:
 - I/P module high circuit is less than 2.4 volts and the I/P module deployment loop is more than 6 ohms for 500 milliseconds.
 - I/P module deployment loop resistance is more than 4.8 ohms for 500 milliseconds.
- DTC B0018 will set when one of the following conditions occur:
 - I/P module high and/or low circuits is short to ground or short to voltage for 500 milliseconds.
 - I/P module high circuit is less than 2.4 volts and I/P module deployment loop resistance is less than 6 ohms for 500 milliseconds.

Action Taken When the DTC Sets

The SDM commands the AIR BAG indicator ON via Class 2 serial data.

Conditions for Clearing the DTC

- The condition responsible for setting the DTC no longer exists and the scan tool Clear DTCs function is used.
- A history DTC will clear once 255 malfunction free ignition cycles have occurred.

Diagnostic Aids

The following are possible causes of the malfunction:

- A short between the I/P module high and low circuits.
- An open or a high resistance in the I/P module high or low circuits.
- A short to ground or a short to voltage in the I/P module high or low circuits.
- The I/P module connector
- The SDM connector

- A malfunctioning I/P module
- A malfunctioning SDM

Thoroughly inspect the wiring and the connectors. An incomplete inspection of the wiring and the connectors may result in a misdiagnosis, causing a part replacement with the reappearance of the malfunction. If an intermittent malfunction exists, refer to **Testing for Intermittent Conditions and Poor Connections** in Wiring Systems.

Test Description

The numbers below refer to the step numbers on the diagnostic table.

4: Tests to see if the malfunction is caused by the I/P module.

6: Tests to see what DTCs are present. If DTC B0016 is present, test the I/P module for a short between high and low circuits. If DTC B0017 is present, test the I/P module high and low circuits for an open and for high resistance. If DTC B0018 is present, test the I/P module high and low circuits for a short to ground and for a short to voltage.

DTC B0016, B0017, or B0018

Step	Action	Yes	No
Schematic Reference: <u>SIR Schematics</u> Connector End View Reference: <u>SIR Connector End Views</u>			
1	Did you perform A Diagnostic System Check - SIR?	Go to Step 2	Go to Diagnostic System Check - SIR
2	1. Turn OFF the ignition. 2. Disconnect I/P module in-line connector. Refer to Inflatable Restraint Instrument Panel Module Replacement . 3. Inspect the component and harness sides of the in-line connector for the I/P module for damage or corrosion that may cause the malfunction. Refer to Testing for Intermittent Conditions and Poor Connections and Connector Repairs in Wiring Systems. Does connectors exhibit any signs of damage or corrosion?	Go to Step 3	Go to Step 4
3	1. If the in-line connector for the IP module is damaged, the I/P module must be replaced. Refer to Inflatable Restraint Instrument Panel Module Replacement . 2. If the wiring harness side of the I/P module in-line connector is damaged, replace the harness side of the connector. Refer to Connector Repairs in Wiring Systems. Did you complete the repair?	Go to Step 9	-
	1. Use the J 38715-100 adapter to connect the J 38715-A SIR		

4	<p>Driver/Passenger Load Tool to the harness side of the IP module in-line connector. See <u>Special Tools and Equipment</u> .</p> <ol style="list-style-type: none"> Turn ON the ignition, with the engine OFF. With the scan tool, request the SIR DTC display. <p>Does the scan tool indicate that DTC B0016, B0017, or B0018 are current?</p>	Go to Step 5	Go to Step 7
5	<ol style="list-style-type: none"> Turn OFF the ignition. Disconnect and remove both the J 38715-A and adapter. See <u>Special Tools and Equipment</u> . Disconnect the inflatable restraint sensing and diagnostic module (SDM) connector. Refer to <u>Inflatable Restraint Sensing and Diagnostic Module Replacement</u> . Inspect the SDM connector for damage or corrosion that may cause a malfunction in the I/P module high and/or low circuits. Refer to <u>Testing for Intermittent Conditions and Poor Connections</u> and <u>Connector Repairs</u> in Wiring Systems. <p>Did you find and correct the condition?</p>	Go to Step 9	Go to Step 6
6	<ol style="list-style-type: none"> If DTC B0016 is present, test the I/P module for a short between the high and low circuits. If DTC B0017 is present, test the I/P module high and low circuits for an open and for high resistance. If DTC B0018 is present, test the I/P module high and low circuits for a short to ground and for a short to voltage. All the above conditions refer to <u>Circuit Testing</u> and <u>Wiring Repairs</u> in Wiring Systems. <p>Did you find and correct the condition?</p>	Go to Step 9	Go to Step 8
7	<ol style="list-style-type: none"> Turn OFF the ignition. Replace the I/P module. Refer to <u>Inflatable Restraint Instrument Panel Module Replacement</u> . <p>Did you complete the replacement?</p>	Go to Step 9	-
8	<ol style="list-style-type: none"> Turn OFF the ignition. Replace the SDM. Refer to <u>Inflatable Restraint Sensing and Diagnostic Module Replacement</u> . <p>Did you complete the replacement?</p>	Go to Step 9	-
	<ol style="list-style-type: none"> Connect all SIR components. Turn ON the ignition, with the engine OFF. 		

9	<p>3. Use the scan tool in order to clear the DTCs.</p> <p>4. Operate the vehicle within the Conditions for Running the DTC as specified in the supporting text.</p>	Go to Step 2	System OK
Does the DTC reset?			

DTC B0022, B0024, OR B0026

Circuit Description

The driver deployment loop consists of a inflatable restraint steering wheel module, the inflatable restraint steering wheel module coil, steering wheel module high and steering wheel module low circuits. There is a shorting bar used within the steering wheel module coil connector which will short together both steering wheel module high circuit and steering wheel module low circuit when the connector is disconnected, this will help to prevent unwanted deployment of the inflator module during servicing. During a frontal crash of sufficient force the inflatable restraint sensing and diagnostic module (SDM) will allow current to flow through the deployment loop in order to deploy the steering wheel module. The SDM performs continuous diagnostic tests on the deployment loops to check for proper circuit continuity and for shorts to ground or voltage. If a malfunction is detected, a diagnostic trouble code (DTC) will be stored in memory.

Conditions for Running the DTC

Ignition 1 voltage is within the normal operating voltage range.

Conditions for Setting the DTC

- DTC B0022 will set when the steering wheel module deployment loop resistance is less than 1.3 ohms for 500 milliseconds.
- DTC B0024 will set when one of the following conditions occur:
 - Steering wheel module high and/or low circuits is short to ground or short to voltage for 500 milliseconds.
 - Steering wheel module high circuit is less than 2.4 volts and steering wheel module deployment loop resistance is less than 6 ohms for 500 milliseconds.
- DTC B0026 will set when one of the following conditions occurs:
 - Steering wheel module high circuit is less than 2.4 volts and the steering wheel module deployment loop is more than 6 ohms for 500 milliseconds.
 - Steering wheel module deployment loop resistance is more than 4.8 ohms for 500 milliseconds.

Action Taken When the DTC Sets

The SDM commands the AIR BAG indicator ON via Class 2 serial data.

Conditions for Clearing the DTC

- The condition responsible for setting the DTC no longer exists and the scan tool Clear DTCs function is

used.

- A history DTC will clear once 255 malfunction free ignition cycles have occurred.

Diagnostic Aids

The following are possible causes of the malfunction:

- A short between the steering wheel module high and low circuits.
- An open or a high resistance in the steering wheel module high or low circuits.
- A short to ground or a short to voltage in the steering wheel module high or low circuits.
- The steering wheel module coil connector
- The SDM connector
- A malfunctioning steering wheel module
- A malfunctioning steering wheel module coil
- A malfunctioning SDM

Thoroughly inspect the wiring and the connectors. An incomplete inspection of the wiring and the connectors may result in a misdiagnosis, causing a part replacement with the reappearance of the malfunction. If an intermittent malfunction exists, refer to **Testing for Intermittent Conditions and Poor Connections** in Wiring Systems.

Test Description

The numbers below refer to the step numbers on the diagnostic table.

5: Tests to see if the malfunction is caused by the steering wheel module or by the steering wheel module coil.

7: Tests to see what DTCs are present. If DTC B0022 is present, test the steering wheel module for a short between high and low circuits. If DTC B0024 is present, test the steering wheel module high and low circuits for an open and for high resistance. If DTC B0026 is present, test the steering wheel module high and low circuits for an open and for high resistance.

DTC B0022, B0024, or B0026

Step	Action	Yes	No
Schematic Reference: <u>SIR Schematics</u> Connector End View Reference: <u>SIR Connector End Views</u> and <u>Inline Harness Connector End Views</u> in Wiring Systems.			
1	Did you perform A Diagnostic System Check - SIR?	Go to Step 2	Go to Diagnostic System Check - SIR
	1. Turn OFF the ignition. 2. Disconnect the steering wheel module coil in-line connector. Refer		

2	<p>to <u>Inflatable Restraint Steering Wheel Module Coil Replacement (Coil)</u> .</p> <p>3. Inspect the component and harness sides of the in-line connector for the steering wheel module coil for damage or corrosion that may cause the malfunction. Refer to <u>Testing for Intermittent Conditions and Poor Connections</u> and <u>Connector Repairs</u> in Wiring Systems.</p>	Go to Step 3	Go to Step 4
3	<p>Does connector exhibits any signs of damage or corrosion?</p> <p>1. If the in-line connector for the steering wheel module coil is damaged, the steering wheel module coil must be replaced. Refer to <u>Inflatable Restraint Steering Wheel Module Coil Replacement (Coil)</u> .</p> <p>2. If the wiring harness side of steering wheel module coil in-line connector is damaged, replace the harness side of the connector. Refer to <u>Connector Repairs</u> in Wiring Systems.</p>	Go to Step 11	-
4	<p>1. Use the J 38715-100 adapter to connect the J 38715-A SIR Driver/Passenger Load Tool to the harness side of the steering wheel module coil in-line connector. See <u>Special Tools and Equipment</u> .</p> <p>2. Turn ON the ignition, with the engine OFF.</p> <p>3. Use the scan tool to request SIR DTCs displayed.</p>	Go to Step 6	Go to Step 5
5	<p>Does the scan tool indicate that DTC B0022, B0024, or B0026 are current?</p> <p>1. Turn OFF the ignition.</p> <p>2. Disconnect and remove both the J 38715-A . See <u>Special Tools and Equipment</u> .</p> <p>3. Connect the steering wheel module coil in-line connector.</p> <p>4. Remove the steering wheel module. Refer to <u>Inflatable Restraint Steering Wheel Module Replacement</u> .</p> <p>5. Use the J 38715-30A adapter to connect the J 38715-A to the upper steering wheel module coil connector on top of the steering column. See <u>Special Tools and Equipment</u> .</p> <p>6. Turn ON the ignition, with the engine OFF.</p> <p>7. Use the scan tool to request SIR DTCs displayed.</p>	Go to Step 9	Go to Step 8
	<p>1. Turn OFF the ignition.</p>		

6	<ol style="list-style-type: none"> 2. Disconnect and remove both the J 38715-A and adapter. See <u>Special Tools and Equipment</u> . 3. Disconnect the inflatable restraint sensing and diagnostic module (SDM) connector. Refer to <u>Inflatable Restraint Sensing and Diagnostic Module Replacement</u> . 4. Inspect the SDM connector for damage or corrosion that may cause a malfunction in the steering wheel module high and/or low circuits. Refer to <u>Testing for Intermittent Conditions and Poor Connections</u> and <u>Connector Repairs</u> in Wiring Systems. <p>Did you find and correct the condition?</p>	Go to Step 11	Go to Step 7
7	<ol style="list-style-type: none"> 1. If DTC B0022 is present, test the steering wheel module for a short between the high and low circuits. 2. If DTC B0024 is present, test the steering wheel module high and low circuits for a short to ground and for a short to voltage. 3. If DTC B0026 is present, test the steering wheel module high and low circuits for an open and for high resistance. 4. All the above conditions refer to <u>Circuit Testing</u> and <u>Wiring Repairs</u> in Wiring Systems. <p>Did you find and correct the condition?</p>	Go to Step 11	Go to Step 10
8	<ol style="list-style-type: none"> 1. Turn OFF the ignition. 2. Replace the steering wheel module. Refer to <u>Inflatable Restraint Steering Wheel Module Replacement</u> . <p>Did you complete the replacement?</p>	Go to Step 11	-
9	<ol style="list-style-type: none"> 1. Turn OFF the ignition. 2. Replace the steering wheel module coil. Refer to <u>Inflatable Restraint Steering Wheel Module Coil Replacement (Coil)</u> . <p>Did you complete the replacement?</p>	Go to Step 11	-
10	<ol style="list-style-type: none"> 1. Turn OFF the ignition. 2. Replace the SDM. Refer to <u>Inflatable Restraint Sensing and Diagnostic Module Replacement</u> . <p>Did you complete the replacement?</p>	Go to Step 11	-
11	<ol style="list-style-type: none"> 1. Connect all SIR components. 2. Turn ON the ignition, with the engine OFF. 3. Use the scan tool in order to clear the DTCs. 4. Operate the vehicle within the Conditions for Running the DTC as specified in the supporting text. 		

Does the DTC reset?

Go to
Step 2

System OK

DTC B0051

Circuit Description

The inflatable restraint sensing and diagnostic module (SDM) contains a sensing device (accelerometer) that converts vehicle velocity to an electrical signal. The SDM compares this signal to a value stored in memory. When the generated signal exceeds the stored value, the SDM performs additional signal processing and compares the generated signals to values stored in memory. When two of the generated signals exceed the stored values, the SDM will cause current to flow through the inflator modules, deploying the air bags and causing DTC B0051 to set.

This DTC is set when the inflatable restraint sensing and diagnostic module (SDM) has commanded an air bag deployment with no faults present.

Conditions for Running the DTC

The SDM must be powered up.

Conditions for Setting the DTC

Ignition voltage must be present and the inflatable restraint sensing and diagnostic module (SDM) must have commanded an air bag deployment.

Action Taken When the DTC Sets

- The SDM commands ON the AIR BAG warning lamp via Class 2 serial data.
- The SDM records crash data.

Conditions for Clearing the DTC

DTC B0051 is a latched code. You cannot clear a latched code. Replace the SDM after following the instructions in the following diagnostic table.

DTC B0051

Step	Action	Value (s)	Yes	No
Schematic Reference: <u>SIR Schematics</u> Connector End View Reference: <u>SIR Connector End Views</u>				
1	Did you perform the Diagnostic System Check - SIR?	-	Go to Step 2	Go to Diagnostic System Check - SIR
	1. Turn OFF the ignition.			

2	2. Inspect the vehicle for any signs of air bag deployment. Does the vehicle exhibit any signs of air bag deployment?	-	Go to Step 5	Go to Step 3
3	Inspect the vehicle and undercarriage for any signs of impact or collision. Does the vehicle exhibit any signs of impact or collision?	-	Go to Step 5	Go to Step 4
4	Replace the inflatable restraint sensing and diagnostic module (SDM). Refer to <u>Inflatable Restraint Sensing and Diagnostic Module Replacement</u> . Did you complete the replacement?	-	Go to Step 6	-
5	Replace all components and perform inspections as required following an accident. Refer to <u>Repairs and Inspections Required After a Collision</u> . Did you complete the appropriate inspections and necessary repairs?	-	Go to Step 6	-
6	1. Reconnect all SIR system components. 2. Verify that all components, connectors, and CPAs are properly mounted. Did you complete the repair?	-	Go to <u>Diagnostic System Check - SIR</u>	-

DTC B0053

Circuit Description

The inflatable restraint sensing and diagnostic module (SDM) contains a sensing device (accelerometer) that converts vehicle velocity to an electrical signal. The SDM compares this signal to a value stored in memory. When the generated signal exceeds the stored value, the SDM performs additional signal processing and compares the generated signals to values stored in memory. When two of the generated signals exceed the stored values, the SDM will cause current to flow through the inflator modules, deploying the air bags. DTC B0053 will set instead of DTC B0051 when a deployment occurs while an inflator circuit fault is present that may result in a non-deployment situation in one or more of the inflator modules.

Conditions for Running the DTC

The SDM must be powered up.

Conditions for Setting the DTC

Ignition voltage must be present and the inflatable restraint sensing and diagnostic module (SDM) must have commanded an air bag deployment with loop faults.

Action Taken When the DTC Sets

- The SDM commands ON the AIR BAG warning lamp via Class 2 serial data.
- The SDM records crash data.

Conditions for Clearing the DTC

DTC B0053 is a latched code. You cannot clear a latched code. Replace the SDM after following the instructions in the following diagnostic table.

Diagnostic Aids

When DTC B0053 is accompanied by additional DTC(s) (other than B0051), repair the malfunction causing the other DTC(s) before replacing the SDM.

DTC B0053

Step	Action	Value (s)	Yes	No
Schematic Reference: <u>SIR Schematics</u> Connector End View Reference: <u>SIR Connector End Views</u>				
1	Did you perform the Diagnostic System Check - SIR?	-	Go to Step 2	Go to Diagnostic System Check - SIR
2	1. Turn OFF the ignition. 2. Inspect the vehicle for any signs of air bag deployment. Does the vehicle exhibit any signs of air bag deployment?	-	Go to Step 5	Go to Step 3
3	Inspect the vehicle and undercarriage for signs of impact or collision. Does the vehicle exhibit any signs of impact or collision?	-	Go to Step 5	Go to Step 4
4	Replace the inflatable restraint sensing and diagnostic module (SDM). Refer to Inflatable Restraint Sensing and Diagnostic Module Replacement . Did you complete the replacement?	-	Go to Step 6	-
5	Replace all components and perform inspections as required following an accident. Refer to Repairs and Inspections Required After a Collision . Did you complete the appropriate inspections and necessary repairs?	-	Go to Step 6	-
	1. Reconnect all SIR system components. 2. Verify that all components, connectors, and			

6	CPAs are properly mounted. Did you complete the repair?	-	Go to <u>Diagnostic System Check - SIR</u>	-
---	--	---	---	---

DTC B0090

Circuit Description

The inflatable restraint I/P module disable switch circuit consists of an I/P module disable switch, I/P module disable switch indicator, I/P module disable switch signal circuit, and I/P module suppression indicator control circuit. When the ignition is turned ON, the inflatable restraint sensing and diagnostic module (SDM) performs tests to diagnose critical malfunctions within itself. The SDM monitors the voltage levels at the I/P module disable switch signal and the I/P module suppression indicator control circuits of the SDM to determine the position of the I/P module disable switch. If a malfunction is detected, a DTC will be stored.

Conditions for Running the DTC

Ignition 1 voltage is within the normal operating voltage range.

Conditions for Setting the DTC

The voltage at I/P module disable switch signal and I/P module suppression indicator control is low or high with the I/P module disable switch indicator OFF for 500 milliseconds.

Action Taken When the DTC Sets

- The I/P module disable switch is defaulted to a calibration state.
- The SDM commands ON the AIR BAG indicator via Class 2 serial data.

Conditions for Clearing the DTC

- The condition responsible for setting the DTC no longer exists.
- You issue a scan tool CLEAR DTCs command.
- A history DTC will clear once 255 malfunction free ignition cycles have occurred.

Diagnostic Aids

The following can cause an intermittent condition:

A short between the I/P module disable switch signal and I/P module suppression indicator control circuits. Refer to **Testing for Intermittent Conditions and Poor Connections** in Wiring Systems.

Test Description

The numbers below refer to the step numbers on the diagnostic table:

5: Tests for an open or high resistance in the I/P module disable switch power feed circuit.

6: Tests for an open or high resistance in the I/P module disable switch ground circuit.

8: Tests for an open or high resistance in the I/P module disable switch signal circuit.

9: Tests for a short in the I/P module disable switch signal circuit.

10: Tests for short in the I/P module suppression indicator control circuit.

11: Tests for an open or high resistance in the I/P module suppression indicator control circuit.

DTC B0090

Step	Action	Value (s)	Yes	No
Schematic Reference: <u>SIR Schematics</u>				
Connector End View Reference: <u>SIR Connector End Views</u>				
1	Did you perform the Diagnostic System Check - SIR?	-	Go to Step 2	Go to Diagnostic System Check - SIR
2	<ol style="list-style-type: none"> 1. Turn OFF the ignition. 2. Turn the I/P module disable switch to the ON position. 3. Turn ON the ignition, with the engine OFF. <p>Does the I/P module disable switch ON indicator illuminate in the I/P module disable switch?</p>	-	Go to Step 7	Go to Step 3
3	<ol style="list-style-type: none"> 1. Turn OFF the ignition. 2. Disconnect the I/P module disable switch connector. Refer to <u>Inflatable Restraint Instrument Panel (I/P) Module Disable Switch Replacement</u> . 3. Inspect the I/P module disable switch connector for corrosion or damage. Refer to <u>Testing for Intermittent Conditions and Poor Connections</u> and <u>Connector Repairs</u> in Wiring Systems. <p>Did you find and correct the condition?</p>	-	Go to Step 13	Go to Step 4
4	<ol style="list-style-type: none"> 1. Disconnect the SDM connector. Refer to <u>Inflatable Restraint Sensing and Diagnostic Module Replacement</u> . 2. Inspect the SDM connector for corrosion or damage. Refer to <u>Testing for Intermittent Conditions and Poor Connections</u> and <u>Connector Repairs</u> in Wiring Systems. <p>Did you find and correct the condition?</p>	-	Go to Step 13	Go to Step 5
5	Test the I/P module disable switch power feed circuit for an open or high resistance. Refer to <u>Circuit Testing</u> and	-	Go to	

	Connector Repairs in Wiring Systems. Did you find and correct the condition?		Step 13	Go to Step 6
6	Test the I/P module disable switch ground circuit for an open or high resistance. Refer to Circuit Testing and Connector Repairs in Wiring Systems. Did you find and correct the condition?	-	Go to Step 13	Go to Step 7
7	<ol style="list-style-type: none"> 1. Install a scan tool. 2. Turn the I/P module disable switch to the ON position. 3. Turn ON the ignition, with the engine OFF. 4. With a scan tool, observe the SIR data list. Does the I/P module disable switch (active switch) show the specified state?	Enabled	Go to Step 9	Go to Step 8
8	<ol style="list-style-type: none"> 1. Turn OFF the ignition. 2. Test the I/P module disable switch signal circuit for an open or high resistance. Refer to Circuit Testing and Connector Repairs in Wiring Systems. Did you find and correct the condition?	-	Go to Step 13	Go to Step 9
9	Test the I/P module disable switch signal circuit for a short. Refer to Circuit Testing and Connector Repairs in Wiring Systems. Did you find and correct the condition?	-	Go to Step 13	Go to Step 10
10	Test the I/P module suppression indicator control circuit for a short. Refer to Circuit Testing and Connector Repairs in Wiring Systems. Did you find and correct the condition?	-	Go to Step 13	Go to Step 11
11	Test the I/P module suppression indicator control circuit for an open or high resistance. Refer to Circuit Testing and Connector Repairs in Wiring Systems. Did you find and correct the condition?	-	Go to Step 13	Go to Step 12
12	Replace the I/P module disable switch. Refer to Inflatable Restraint Instrument Panel (I/P) Module Disable Switch Replacement . Did you complete the repair?	-	Go to Step 13	-
13	<ol style="list-style-type: none"> 1. Reconnect all SIR system components. 2. Verify that all components, connectors and CPAs are properly mounted. 3. Use the scan tool in order to clear the DTCs. 4. Operate the vehicle within the Conditions for Running the DTC as specified in the supporting text. Does the DTC reset?	-	Go to Step 2	System OK

DTC B0091

Circuit Description

The inflatable restraint I/P module disable switch circuit consists of an I/P module disable switch, I/P module disable switch indicator, I/P module disable switch signal circuit, and I/P module suppression indicator control circuit. When the ignition is turned ON, the inflatable restraint sensing and diagnostic module (SDM) performs tests to diagnose critical malfunctions within itself. The SDM monitors the voltage levels at the I/P module disable switch signal and the I/P module suppression indicator control circuits of the SDM to determine the position of the I/P module disable switch. If a malfunction is detected, a DTC will be stored.

Conditions for Running the DTC

Ignition 1 voltage is within the normal operating voltage range.

Conditions for Setting the DTC

The voltage at I/P module disable switch signal is low with the I/P module disable switch indicator ON and the voltage at I/P module suppression indicator control is high for 500 milliseconds.

Action Taken When the DTC Sets

- The I/P module disable switch is defaulted to a calibrated state.
- The SDM commands ON the AIR BAG indicator via Class 2 serial data.
- The SDM toggles the I/P module disable switch AIR BAG indicator ON and OFF every 5 seconds.

Conditions for Clearing the DTC

- The condition responsible for setting the DTC no longer exists.
- You issue a scan tool CLEAR DTCs command.
- A history DTC will clear once 255 malfunction free ignition cycles have occurred.

Diagnostic Aids

The following can cause an intermittent condition:

A short between the I/P module disable switch signal and the I/P module suppression indicator control circuits. Refer to **Testing for Intermittent Conditions and Poor Connections** in Wiring Systems.

Test Description

The numbers below refer to the step numbers on the diagnostic table.

- 3:** Observes the state of the I/P module disable switch, normal state being ON.
- 4:** Tests for a malfunctioning I/P module disable switch.
- 5:** Tests for a malfunctioning SDM.

6: Tests for a short in the I/P module disable switch signal circuit.

7: Tests for a short in the I/P module suppression indicator control circuit.

DTC B0091

Step	Action	Yes	No
Schematic Reference: <u>SIR Schematics</u> Connector End View Reference: <u>SIR Connector End Views</u>			
1	Did you perform the Diagnostic System Check - SIR?	Go to Step 2	Go to Diagnostic System Check - SIR
2	<ol style="list-style-type: none"> 1. Turn OFF the ignition. 2. Disconnect the I/P module disable switch. Refer to <u>Inflatable Restraint Instrument Panel (I/P) Module Disable Switch Replacement</u> . 3. Inspect the I/P module disable switch connector for corrosion or damage. Refer to <u>Testing for Intermittent Conditions and Poor Connections</u> and <u>Connector Repairs</u> in Wiring Systems. <p>Did you find and correct the condition?</p>	Go to Step 11	Go to Step 3
3	<ol style="list-style-type: none"> 1. Reconnect the I/P module disable switch connector. 2. Turn the I/P module disable switch to the OFF position. 3. Turn ON the ignition, with the engine OFF. 4. With a scan tool, observe the I/P module disable switch (active switch) data parameter in the SDM inputs list. <p>Does the scan tool indicate that the I/P module disable switch (active switch) is DISABLED?</p>	Go to Step 4	Go to Step 5
4	<ol style="list-style-type: none"> 1. Turn the I/P module disable switch to the ON position. 2. With a scan tool, observe the I/P module disable switch (active switch) data parameter. <p>Does the I/P module disable switch (active switch) data parameter change state?</p>	Go to Diagnostic Aids	Go to Step 5
5	<ol style="list-style-type: none"> 1. Turn OFF the ignition. 2. Disconnect the I/P module disable switch. Refer to <u>Inflatable Restraint Instrument Panel (I/P) Module Disable Switch Replacement</u> . 3. Turn ON the ignition, with the engine OFF. 4. With a scan tool, observe the I/P module disable switch (active switch) data parameter. 		

	Does the scan tool indicate that the I/P module disable switch (active switch) is DISABLED?	Go to Step 10	Go to Step 6
6	Test the I/P module disable switch signal circuit for a short. Refer to Circuit Testing and Wiring Repairs in Wiring Systems. Did you find and correct the condition?	Go to Step 11	Go to Step 7
7	Test the I/P module suppression indicator control circuit for a short. Refer to Circuit Testing and Wiring Repairs in Wiring Systems. Did you find and correct the condition?	Go to Step 11	Go to Step 8
8	<ol style="list-style-type: none"> 1. Turn OFF the ignition. 2. Disconnect the SDM connector. Refer to Inflatable Restraint Sensing and Diagnostic Module Replacement . 3. Inspect the SDM connector for corrosion or damage. Refer to Testing for Intermittent Conditions and Poor Connections and Connector Repairs in Wiring Systems. Did you find and correct the condition?	Go to Step 11	Go to Step 9
9	Replace the SDM. Refer to Inflatable Restraint Sensing and Diagnostic Module Replacement . Did you complete the replacement?	Go to Step 11	-
10	Replace the I/P module disable switch. Refer to Inflatable Restraint Instrument Panel (I/P) Module Disable Switch Replacement . Did you complete the replacement?	Go to Step 11	-
11	<ol style="list-style-type: none"> 1. Reconnect all SIR system components. 2. Verify that all components, connectors and CPAs are properly mounted. 3. Use the scan tool in order to clear the DTCs. 4. Operate the vehicle within the Conditions for Running the DTC as specified in the supporting text. Does the DTC reset?	Go to Step 2	System OK

DTC B0100, B0101, B0102, B0103, B0104, OR B0105

Circuit Description

The inflatable restraint electronic frontal sensor (EFS) utilizes a unidirectional 2-wire circuit. The EFS modulates current on the interface to send ID, State of Health, and deployment commands to the inflatable restraint sensing and diagnostic module (SDM). The SDM serves as a power source and a ground for the EFS. When the ignition is turned on and input power from the SDM is first detected, the EFS responds by performing internal diagnostics and sending an ID to the SDM. The SDM considers the ID to be valid if the response time is less than 5 seconds. The EFS continually communicates status messages to the SDM, which determines if a

fault is present in the EFS circuit. When a fault is detected, the SDM may reset the EFS up to two times by removing and reapplying power to it. If the fault is still present, the SDM will set a diagnostic trouble code (DTC).

Conditions for Running the DTC

Ignition 1 Voltage is within the normal operating voltage range of 9-16 volts.

Conditions for Setting the DTC

- DTC B0100 for the EFS-LF or B0103 for the EFS-RF will set when one of the following conditions occur:
 - A valid ID message is not received within 5 seconds of the EFS being powered up.
 - A status message is not received.
 - The SDM has reset the EFS twice without detecting a valid ID message.
- DTC B0101 for the EFS-LF or B0104 for the EFS-RF will set when the SDM has received a NOK message from the EFS.
- DTC B0102 for the EFS-LF or B0105 for the EFS-RF will set when one of the following conditions occur:
 - The SDM has received an ID message from the EFS which does not match the ID stored in the SDM memory.
 - The SDM has reset the EFS twice without detecting the correct ID message.

Action Taken When the DTC Sets

The SDM commands ON the AIR BAG warning lamp via Class 2 serial data.

Conditions for Clearing the DTC

- The DTC will clear when the condition responsible for setting the DTC no longer exists and the scan tool Clear DTCs function is used.
- A history DTC will clear once 255 malfunction free ignition cycles have occurred.

Diagnostic Aids

The following are conditions that may cause the malfunction:

- A short to ground or voltage in the EFS circuit
- High or low resistance in the EFS circuit
- Improper EFS installed on vehicle

Thoroughly inspect the wiring and the connectors. An incomplete inspection of the wiring and connectors may result in misdiagnosis, causing a part replacement with the reappearance of the malfunction. If an intermittent malfunction exists, refer to **Testing for Intermittent Conditions and Poor Connections** in Wiring Systems.

Test Description

The numbers below refer to the step numbers on the diagnostic table.

7: Tests the EFS signal and EFS voltage circuits for an open or high resistance

8: Tests between the EFS signal and EFS voltage circuits for continuity

9: Tests the EFS signal and EFS voltage circuits for a short to voltage

DTC B0100, B0101, B0102, B0103, B0104, or B0105

Step	Action	Yes	No
Schematic Reference: <u>SIR Schematics</u> Connector End View Reference: <u>SIR Connector End Views</u>			
1	Did you perform the Diagnostic System Check - SIR?	Go to Step 2	Go to <u>Diagnostic System Check - SIR</u>
2	<ol style="list-style-type: none">1. Install a scan tool.2. Turn ON the ignition, with the engine OFF.3. Use the scan tool to request SIR DTCs displayed. Does the scan tool indicate that DTC B0101, B0102, B0104, or B0105 is current?	Go to Step 10	Go to Step 3
3	<ol style="list-style-type: none">1. Turn OFF the ignition.2. If DTC B0100 is current, disconnect the inflatable restraint electronic frontal sensor (EFS) - LF connector. If DTC B0103 is current, disconnect the EFS-RF connector. The EFS is also known as the inflatable restraint front end discriminating sensor. Refer to <u>Inflatable Restraint Front End Sensor Replacement</u> .3. Inspect both the component and harness sides of the connector for damage or corrosion. Refer to <u>Testing for Intermittent Conditions and Poor Connections</u> in Wiring Systems. Does the connector exhibit any signs of damage or corrosion?	Go to Step 4	Go to Step 5
4	<ol style="list-style-type: none">1. If the component side of the EFS connector is damaged, the EFS must be replaced. Refer to <u>Inflatable Restraint Front End Sensor Replacement</u> .2. If the harness side of the EFS connector is damaged, replace the harness side of the connector. Refer to <u>Connector Repairs</u> in Wiring Systems. Did you complete the repair?	Go to Step 11	-
	<ol style="list-style-type: none">1. Turn OFF the ignition.2. Disconnect the Inflatable Restraint Sensing and Diagnostic Module		

5	<p>(SDM) connector. Refer to <u>Inflatable Restraint Sensing and Diagnostic Module Replacement</u> .</p> <p>3. Inspect both the component and harness sides of the SDM connector for damage or corrosion. Refer to <u>Testing for Intermittent Conditions and Poor Connections</u> in Wiring Systems.</p> <p>Does the connector exhibit any signs of damage or corrosion?</p>	Go to Step 6	Go to Step 7
6	<p>1. If the component side of the SDM connector is damaged, the SDM must be replaced. Refer to <u>Inflatable Restraint Sensing and Diagnostic Module Replacement</u> .</p> <p>2. If the harness side of the SDM connector is damaged, replace the harness side of the connector. Refer to <u>Connector Repairs</u> in Wiring Systems.</p> <p>Did you complete the repair?</p>	Go to Step 11	-
7	<p>1. If DTC B0100 is current, disconnect the EFS-LF connector. If DTC B0103 is current, disconnect the EFS-RF connector.</p> <p>2. Test both the EFS signal and EFS voltage circuits for an open or high resistance between the SDM connector and the EFS connector. Refer to <u>Circuit Testing</u> and <u>Wiring Repairs</u> in Wiring Systems.</p> <p>Did you find and correct the condition?</p>	Go to Step 11	Go to Step 8
8	<p>Test for continuity between the EFS signal circuit and the EFS voltage circuit on the SDM connector. Refer to <u>Circuit Testing</u> and <u>Wiring Repairs</u> in Wiring Systems.</p> <p>Did you find and correct the condition?</p>	Go to Step 11	Go to Step 9
9	<p>1. Turn ON the ignition, with the engine OFF.</p> <p>2. Test both EFS signal and EFS voltage circuits for a short to voltage. Refer to <u>Circuit Testing</u> and <u>Wiring Repairs</u> in Wiring Systems.</p> <p>Did you find and correct the condition?</p>	Go to Step 11	Go to Step 10
10	<p>1. Turn OFF the ignition.</p> <p>2. If DTC B0100, B0101, or B0102 was current replace the EFS-LF. If DTC B0103, B0104, or B0105 was current replace the EFS-RF. The EFS is also known as the inflatable restraint front end discriminating sensor. Refer to <u>Inflatable Restraint Front End Sensor Replacement</u> .</p> <p>Did you complete the replacement?</p>	Go to Step 11	-
11	<p>1. Reconnect all SIR components.</p> <p>2. Use the scan tool in order to Clear the DTCs.</p> <p>3. Operate the vehicle within the Conditions for Running the DTC as specified in the text.</p>	Go to	

	Does the DTC reset?	Step 12	System OK
12	<ol style="list-style-type: none"> 1. Turn OFF the ignition. 2. Replace the SDM. Refer to <u>Inflatable Restraint Sensing and Diagnostic Module Replacement</u> . <p>Did you complete the replacement?</p>	Go to Step 13	-
13	<ol style="list-style-type: none"> 1. Turn ON the ignition, with the engine OFF 2. Use the scan tool in order to Clear the DTCs. 3. Operate the vehicle within the Conditions for Running the DTC as specified in the text. <p>Does the DTC reset?</p>	Go to Step 2	System OK

DTC B1001

Circuit Description

When the ignition is turned ON, the inflatable restraint sensing and diagnostic module (SDM) compares the restraints ID stored in the SDM to the restraints ID stored in the body control module (BCM). The restraints ID being compared contains the last four digits of the SDM part number. For more detailed information concerning Class 2 serial data lines, refer to **Data Link Communications Description and Operation** in Data Link Communications.

Conditions for Running the DTC

Ignition 1 voltage is within the normal operating voltage range.

Action Taken When the DTC Sets

- The SDM disables all AIR BAG deployments.
- The SDM commands the AIR BAG indicator ON via Class 2 serial data.

Conditions for Clearing the DTC

- The condition responsible for setting the DTC no longer exists.
- You issue a scan tool CLEAR DTCs command.
- A history DTC will clear once 255 malfunction free ignition cycles have occurred.

Diagnostic Aids

DTC B1001 is an indication that the restraints ID stored in both the BCM and SDM do not match. If either the BCM or PCM were replaced, the replacement modules need to be reprogrammed for proper operation. In addition, if the BCM or SDM were replaced, the vehicle theft deterrent (VTD) system will also need to be

reprogrammed.

Test Description

The numbers below refer to the step numbers on the diagnostic table.

2: This step checks to see if the correct VIN is programmed in the PCM.

3: This step explains the proper steps to perform after a PCM has been replaced in order for the PCM to operate properly.

5: This step explains the proper steps to perform after a BCM has been replaced in order for the BCM to operate properly.

8: This step explains how to properly program the vehicle theft deterrent (VTD) system.

DTC B1001

Step	Action	Yes	No
Schematic Reference: <u>SIR Schematics</u> Connector End View Reference: <u>SIR Connector End Views</u>			
1	Did you perform the Diagnostic System Check - SIR?	Go to Step 2	Go to Diagnostic System Check - SIR
2	1. Install a scan tool. 2. Turn ON the ignition, with the engine OFF. 3. With a scan tool, verify that the PCM is programmed with the correct VIN by comparing the VIN that is stored in the PCM to the VIN plate of the vehicle. Is the PCM programmed with the correct VIN?	Go to Step 4	Go to Step 3
3	With a scan tool and/or techline machine, program the correct VIN into the PCM. Refer to PCM programming in Engine Controls. Did you complete the programming procedure?	Go to Step 9	-
4	Was the BCM replaced?	Go to Step 5	Go to Step 6
5	Program the BCM in order for the BCM to learn the restraints ID from the SDM. Refer to Body Control Module (BCM) Programming/RPO Configuration in Body Control System. Did you complete the programming procedures?	Go to Step 8	-
6	Was the SDM replaced?	Go to Step 8	Go to Step 7
7	Replace the SDM. Refer to Inflatable Restraint Sensing and Diagnostic Module Replacement . Did you complete the replacement?	Go to Step 8	-
	IMPORTANT: Use the scan tool to perform the VTD relearn. Do not use the 30 minute manual learn procedure.		

8	Reprogram the vehicle theft deterrent (VTD) system. Refer to <u>Programming Theft Deterrent System Components</u> in Theft Deterrent. Did you complete the reprogramming procedure?	Go to Step 9	-
9	<ol style="list-style-type: none"> 1. Verify that all components, connectors, and CPAs are properly mounted. 2. Use the scan tool in order to clear the DTCs. 3. Operate the vehicle within the Conditions for Running the DTC as specified in the supporting text. <p>Does the DTC reset?</p>	Go to Step 2	System OK

SYMPTOMS - SIR

IMPORTANT: The following steps must be completed before using the Symptom Tables.

1. Perform the **Diagnostic System Check - SIR** before using the Symptom Tables in order to verify that all of the following are true:
 - There are no DTCs set.
 - The control module(s) can communicate via the serial data link.
2. Review the system operation in order to familiarize yourself with the system functions. Refer to **SIR System Description and Operation** .

Visual/Physical Inspection

- Inspect for aftermarket devices which could affect the operation of the SIR system. Refer to **Checking Aftermarket Accessories** in Wiring Systems.
- Inspect the easily accessible or visible system components for obvious damage or conditions which could cause the symptom.

Intermittent

Faulty electrical connections or wiring may be the cause of intermittent conditions. Refer to **Testing for Intermittent Conditions and Poor Connections** in Wiring Systems.

Symptom List

Refer to **Air Bag Indicator Circuit Malfunction** in order to diagnose the symptom.

AIR BAG INDICATOR CIRCUIT MALFUNCTION

Circuit Description

The AIR BAG warning lamp is controlled by the inflatable restraint sensing and diagnostic module (SDM) via Class 2 serial data. When the ignition switch is first turned to the RUN position, the SDM performs tests to

diagnose critical malfunctions within itself. The SDM then commands the AIR BAG warning lamp OFF after it has flashed seven times.

Diagnostic Aids

- If Ignition 1 voltage is outside of the normal operating voltage range (9-16 volts), the AIR BAG warning lamp will come ON solid with no DTCs set.
- The loss of serial data communication between the inflatable restraint sensing and diagnostic module (SDM) and the instrument panel cluster (IPC), will cause the AIR BAG warning lamp to come ON solid. Refer to **DTC U1001-U1254** in Data Link Communications.

Test Description

The number(s) below refer to the step number(s) on the diagnostic table.

- 3:** This step checks to see if the AIR BAG warning lamp flashes seven times when the ignition switch is first turned to the RUN position.
- 4:** This step checks to see if DTC U1088 is present in the instrument panel cluster (IPC).
- 5:** This step checks to see if the AIR BAG warning lamp can be commanded ON.
- 6:** This step checks to see if ignition 1 voltage to the SDM is more than 9 V.
- 7:** This step determines if ignition 1 voltage to the SDM is more than 16 V or if there is a malfunctioning SDM.
- 8:** This step inspects the SDM wiring harness connector for corrosion or damage.
- 10:** Tests for an open or high resistance in the ignition 1 voltage circuit between the SDM and the SIR Fuse.
- 12:** Tests for an open or high resistance in the ignition 1 voltage circuit to the SIR Fuse.
- 14:** Tests for an open or high resistance in the SDM ground circuit or if there is a malfunctioning SDM.

Air Bag Indicator Circuit Malfunction

Step	Action	Value (s)	Yes	No
Schematic Reference: <u>SIR Schematics</u>				
Connector End View Reference: <u>SIR Connector End Views</u>				
1	Did you perform the SIR Diagnostic System Check?	-	Go to Step 2	Go to Diagnostic System Check - SIR
2	Did you perform the Instrument Cluster Diagnostic System Check?	-	Go to Step 3	Go to Diagnostic System Check - Instrument Cluster in Instrument Panel, Gauges and Console
3	1. Turn OFF the ignition. 2. Observe the AIR BAG warning lamp while turning the ignition switch to the	-		

	RUN position. Does the AIR BAG warning lamp flash seven times?		Go to Step 4	Go to Step 17
4	<ol style="list-style-type: none"> 1. Install a scan tool. 2. Establish communication with the instrument cluster. 3. Use the scan tool to request the instrument cluster DTC display. <p>Does the scan tool indicate that DTC U1088 is current?</p>	-	Go to DTC U1001-U1254 in Data Link Communications	Go to Step 5
5	Use the scan tool to command the AIR BAG warning lamp ON. Does the AIR BAG warning lamp command ON?	-	Go to Step 6	Go to Step 17
6	<ol style="list-style-type: none"> 1. Establish communication with the inflatable restraint sensing and diagnostic module (SDM). 2. Use the scan tool to request the SIR DTC display. <p>Does the ignition voltage displayed measure more than the specified value?</p>	9 V	Go to Step 7	Go to Step 8
7	Does the ignition voltage displayed measure more than the specified value?	16 V	Go to Diagnostic System Check - Engine Electrical in Engine Electrical	Go to Step 16
8	<ol style="list-style-type: none"> 1. Turn OFF the ignition. 2. Disconnect the inflatable restraint sensing and diagnostic module (SDM) wiring harness connector. Refer to <u>Inflatable Restraint Sensing and Diagnostic Module Replacement</u> . 3. Inspect the SDM wiring harness connector for signs of corrosion or damage. <p>Does the connector exhibit any signs of corrosion or damage?</p>	-	Go to Step 9	Go to Step 10
9	Repair or replace the inflatable restraint sensing and diagnostic module (SDM) wiring harness connector. Refer to <u>Connector Repairs</u> in Wiring Systems.	-		-

	Did you complete the replacement?		Go to Step 18	
10	<ol style="list-style-type: none"> 1. Disable the SIR system. 2. Using J 39200 DMM measure the resistance between the inflatable restraint sensing and diagnostic module (SDM) wiring harness connector ignition 1 circuit and the output side of the SIR Fuse. Refer to Circuit Testing in Wiring Systems. <p>Does the resistance measure within the specified value?</p>	0-2 ohm	Go to Step 12	Go to Step 11
11	<p>Locate and repair an open or high resistance in the ignition 1 circuit between the SIR Fuse and the SDM wiring harness connector. Refer to Wiring Repairs in Wiring Systems. Did you complete the repair?</p>	-	Go to Step 18	-
12	<ol style="list-style-type: none"> 1. Turn ON the ignition, with the engine OFF. 2. Using J 39200 DMM measure the voltage between the power feed to the SIR Fuse and a known good ground. Refer to Circuit Testing in Wiring Systems. <p>Does the voltage measure near the specified value?</p>	12 V	Go to Step 14	Go to Step 13
13	<p>Locate and repair an open or high resistance in the power feed circuit to the SIR Fuse. Refer to Wiring Repairs in Wiring Systems. Did you complete the repair?</p>	-	Go to Step 18	-
14	<p>Using J 39200 DMM measure the resistance of the inflatable restraint sensing and diagnostic module (SDM) ground circuit between the SDM wiring harness connector and a known good ground. Refer to Circuit Testing in Wiring Systems. Does the resistance measure less than the specified value?</p>	2 ohm	Go to Step 16	Go to Step 15
15	<p>Locate and repair an open or high resistance in the inflatable restraint sensing and diagnostic module (SDM) ground circuit. Refer to Wiring Repairs in Wiring Systems. Did you find and correct the condition?</p>	-	Go to Step 18	-
	Replace the inflatable restraint sensing and			

16	diagnostic module (SDM). Refer to <u>Inflatable Restraint Sensing and Diagnostic Module Replacement</u> . Did you complete the replacement?	-	Go to Step 18	-
17	Replace the instrument cluster. Refer to <u>Instrument Panel Cluster (IPC) Replacement</u> in Instrument Panel, Gauges and Console. Did you complete the replacement?	-	Go to Step 18	-
18	<ol style="list-style-type: none"> 1. Reconnect all SIR and Instrument Cluster system components. 2. Verify that all components, connectors, and CPAs are properly mounted. <p>Have all SIR and Instrument Cluster components been properly connected and mounted?</p>	-	Go to <u>Diagnostic System Check - SIR</u>	-

SIR DISABLING AND ENABLING ZONES

IMPORTANT: Refer to SIR Service Precautions before disabling the SIR system.

The SIR system has been divided into Disabling and Enabling Zones. When performing service on or near SIR components or SIR wiring, it may be necessary to disable the SIR components in that zone. It may be necessary to disable more than one zone depending on the location of other SIR components and the area being serviced, refer to **SIR Zone Identification Views** . Refer to the illustration below, to identify the specific zone or zones in which service will be performed. After identifying the zone or zones, proceed to the disabling and enabling procedures for that particular zone or zones.

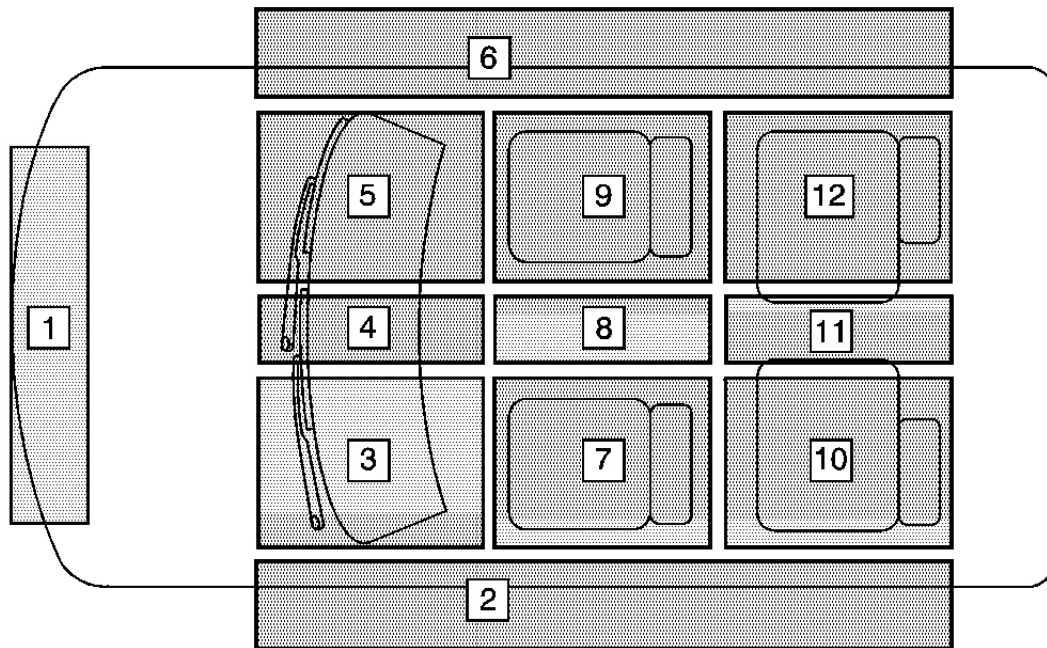

Fig. 5: SIR Disabling and Enabling Zones
 Courtesy of GENERAL MOTORS CORP.

SIR Disabling and Enabling Zones

Zone	Description
1	Inflatable Restraint Electronic Frontal Sensors (EFS). Refer to <u>SIR Disabling and Enabling Zone 1</u> .
2	Not Used
3	Inflatable Restraint Steering Wheel Module and Coil. Refer to <u>SIR Disabling and Enabling Zone 3</u> .
4	Not Used
5	Inflatable Restraint Instrument Panel (I/P) Module. Refer to <u>SIR Disabling and Enabling Zone 5</u> .
6	Not Used
7	Inflatable Restraint Sensing and Diagnostic Module (SDM). Refer to <u>SIR Disabling and Enabling Zone 7</u> .
8-12	Not Used

REPAIR INSTRUCTIONS

SIR SERVICE PRECAUTIONS

CAUTION: When performing service on or near the SIR components or the SIR wiring, the SIR system must be disabled. Refer to SIR Disabling and Enabling Zones. Failure to observe the correct procedure could cause deployment of the SIR components, personal injury, or unnecessary SIR system repairs.

The inflatable restraint sensing and diagnostic module (SDM) maintains a reserved energy supply. The reserved energy supply provides deployment power for the air bags. Deployment power is available for as much as 1 minute after disconnecting the vehicle power. Disabling the SIR system prevents deployment of the air bags from the reserved energy supply.

General Service Instructions

The following are general service instructions which must be followed in order to properly repair the vehicle and return it to its original integrity:

- Do not expose inflator modules to temperatures above 65°C (150°F).
- Verify the correct replacement part number. Do not substitute a component from a different vehicle.
- Use only original GM replacement parts available from your authorized GM dealer. Do not use salvaged parts for repairs to the SIR system.

Discard any of the following components if it has been dropped from a height of 91 cm (3 ft) or greater:

- Inflatable restraint electronic frontal sensor (EFS)
- Inflatable restraint I/P module
- Inflatable restraint sensing and diagnostic module (SDM)
- Inflatable restraint steering wheel module
- Inflatable restraint steering wheel module coil

SIR DISABLING AND ENABLING ZONE 1

IMPORTANT: Refer to SIR Service Precautions before disabling the SIR system.

Disabling Procedure

1. Turn the steering wheel so that the vehicle's wheels are pointing straight ahead.
2. Turn OFF the ignition.
3. Remove the key from the ignition.
4. Remove the engine protection shield, if equipped.

IMPORTANT: With the SIR fuse removed and the ignition ON, the AIR BAG indicator illuminates. This is normal operation and does not indicate an SIR system malfunction.

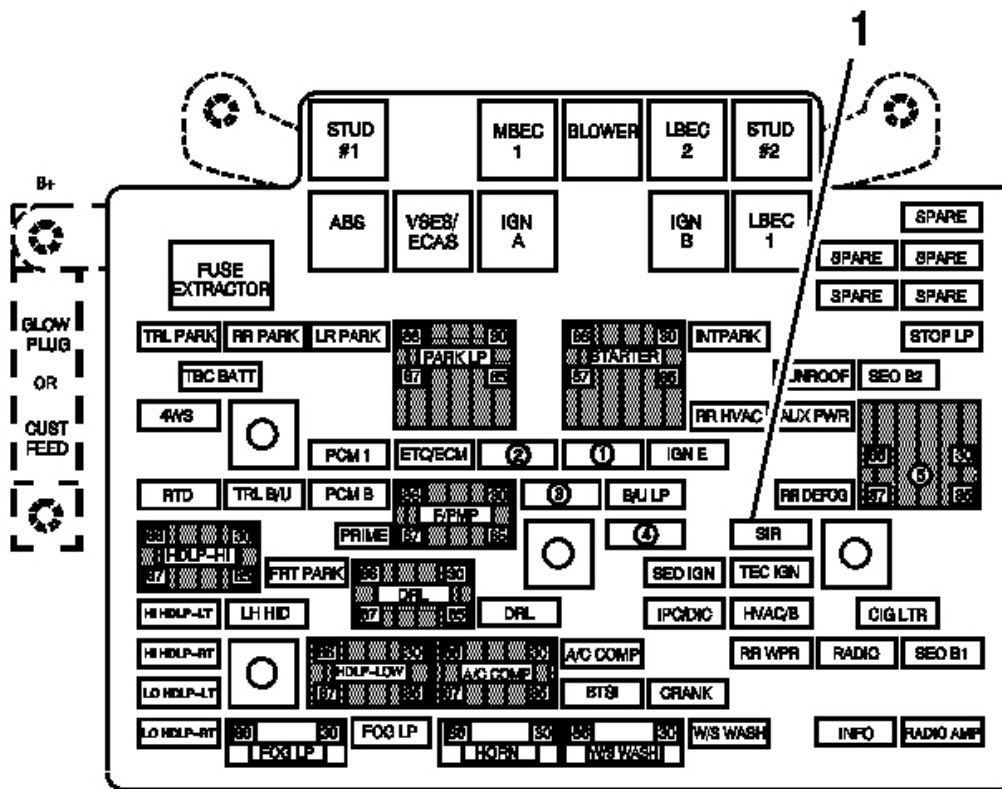

Fig. 6: SIR Fuse & Underhood Fuse Block
 Courtesy of GENERAL MOTORS CORP.

5. Remove the SIR fuse (1) from the underhood fuse block.
6. Raise and support the vehicle.

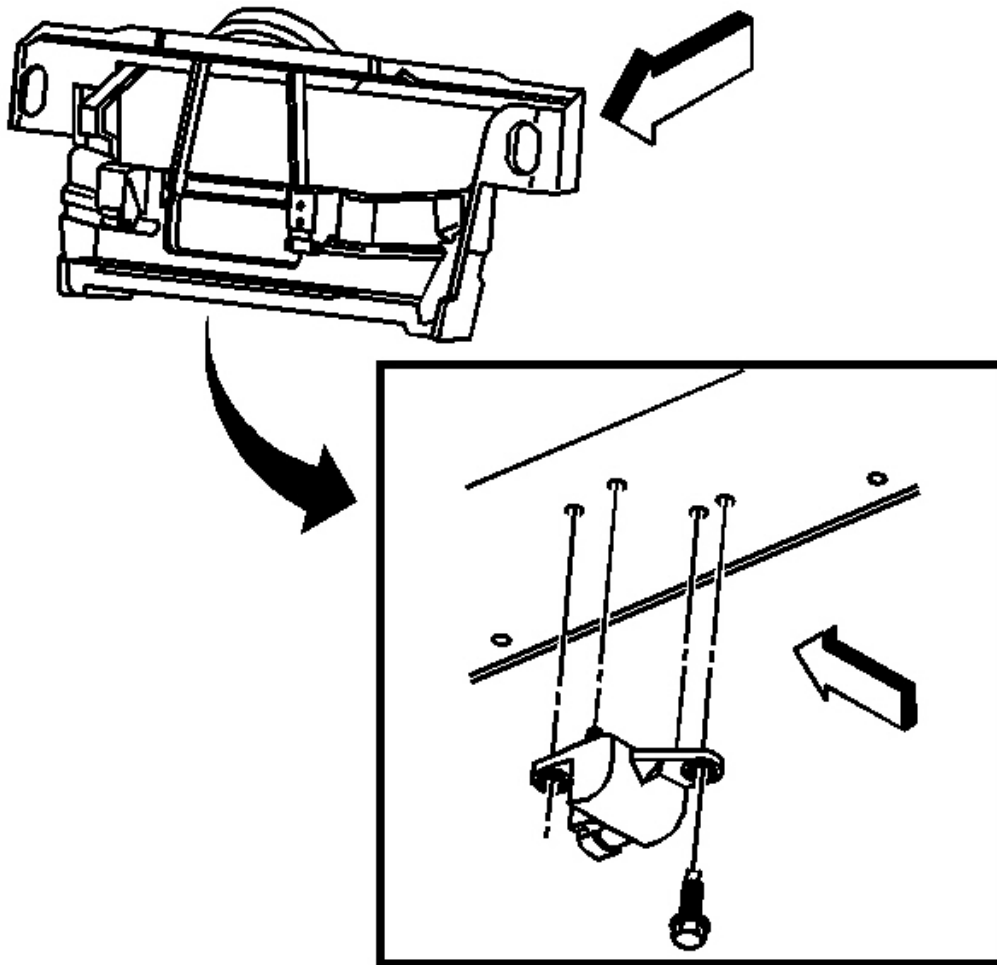

Fig. 7: CPA & EFS Connectors Located On The Frame Crossmember
Courtesy of GENERAL MOTORS CORP.

7. Remove the connector position assurance (CPA) from both electronic frontal sensor (EFS) connectors located on the frame crossmember.
8. Disconnect the EFS connectors.

Enabling Procedure

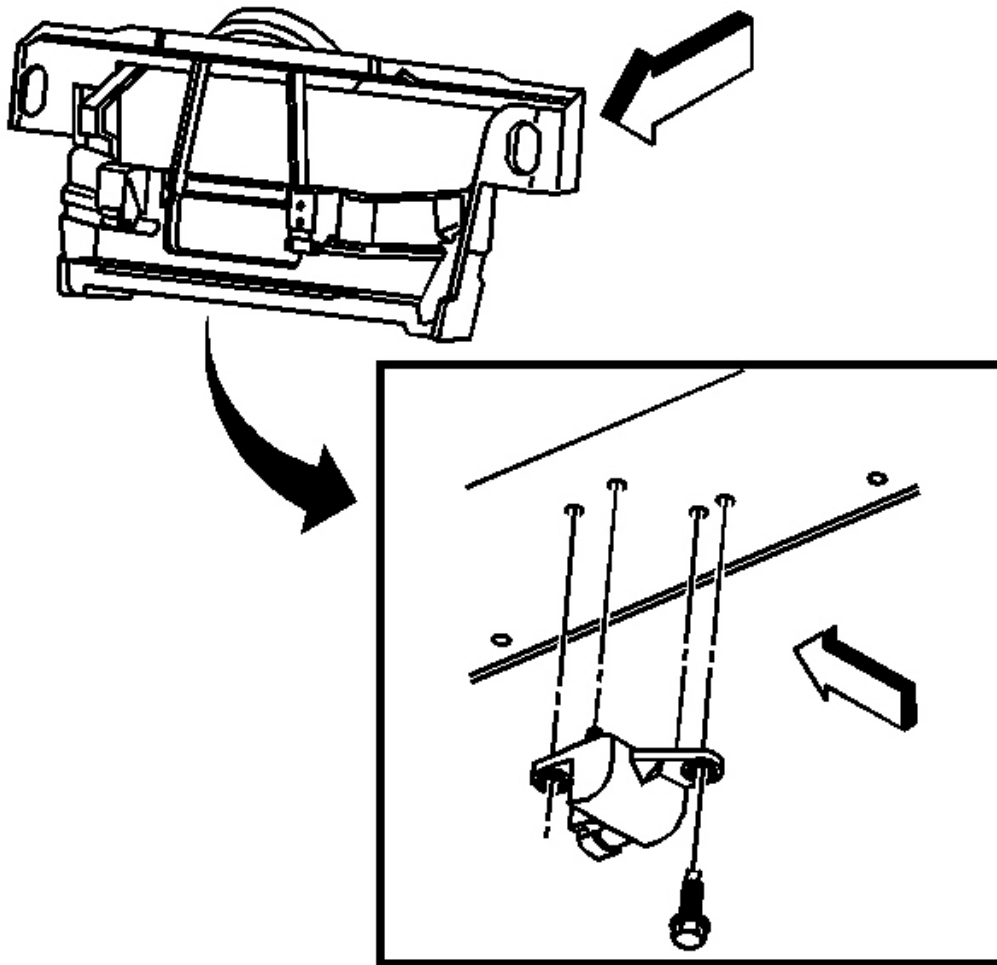

Fig. 8: CPA & EFS Connectors Located On The Frame Crossmember
Courtesy of GENERAL MOTORS CORP.

1. Connect the EFS connectors to the EFS.
2. Install the CPA to the EFS connectors.

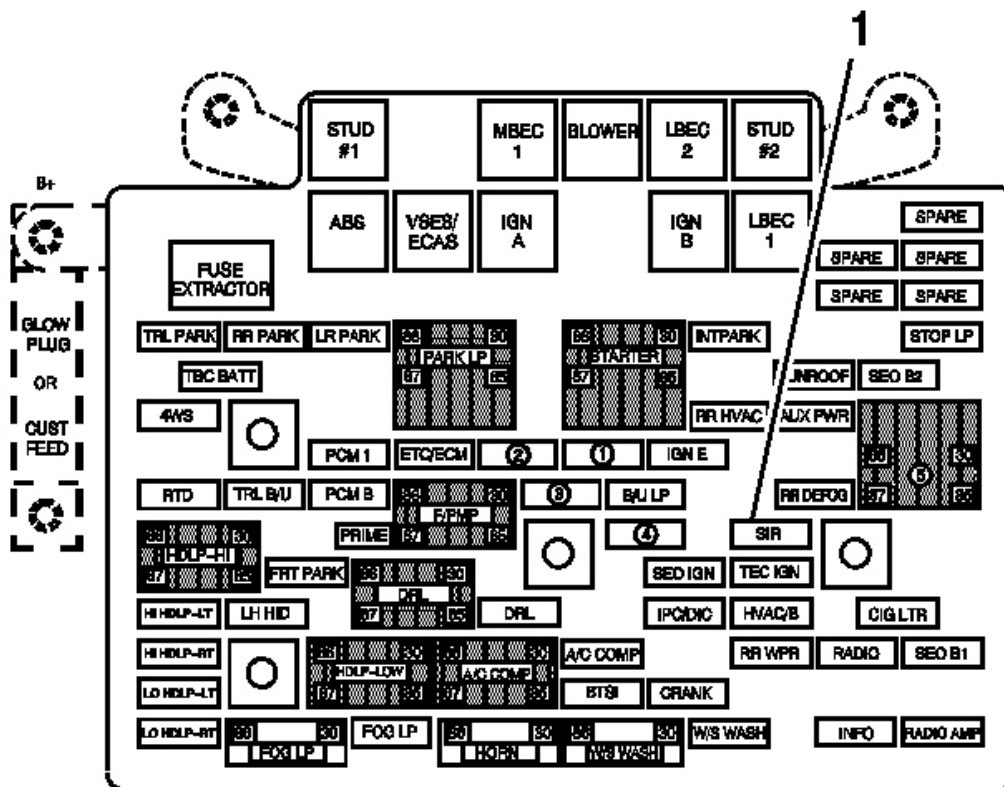

Fig. 9: SIR Fuse & Underhood Fuse Block
 Courtesy of GENERAL MOTORS CORP.

3. Install the SIR fuse (1) into the underhood fuse block.
4. Staying well away from all air bags, turn ON the ignition, with the engine OFF.
 1. The AIR BAG indicator will flash 7 times.
 2. The AIR BAG indicator will then turn OFF.
5. Perform the **Diagnostic System Check - SIR** if the AIR BAG indicator does not operate as described.

SIR DISABLING AND ENABLING ZONE 3

IMPORTANT: Refer to SIR Service Precautions before disabling the SIR system.

Disabling Procedure

1. Turn the steering wheel until the vehicle's wheels are pointing straight ahead.

2. Turn OFF the ignition.
3. Remove the key from the ignition.

IMPORTANT: With the SIR fuse removed and the ignition ON, the AIR BAG indicator illuminates. This is normal operation and does not indicate an SIR system malfunction.

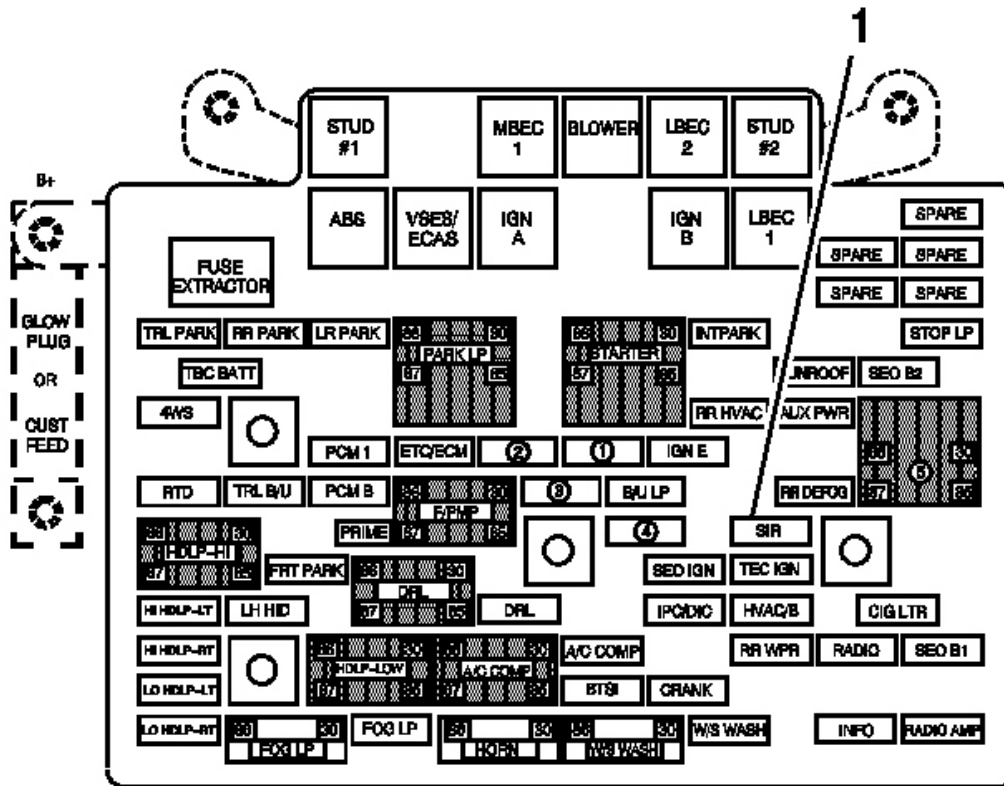

Fig. 10: SIR Fuse & Underhood Fuse Block
 Courtesy of GENERAL MOTORS CORP.

4. Remove the SIR fuse (1) from the underhood fuse block.

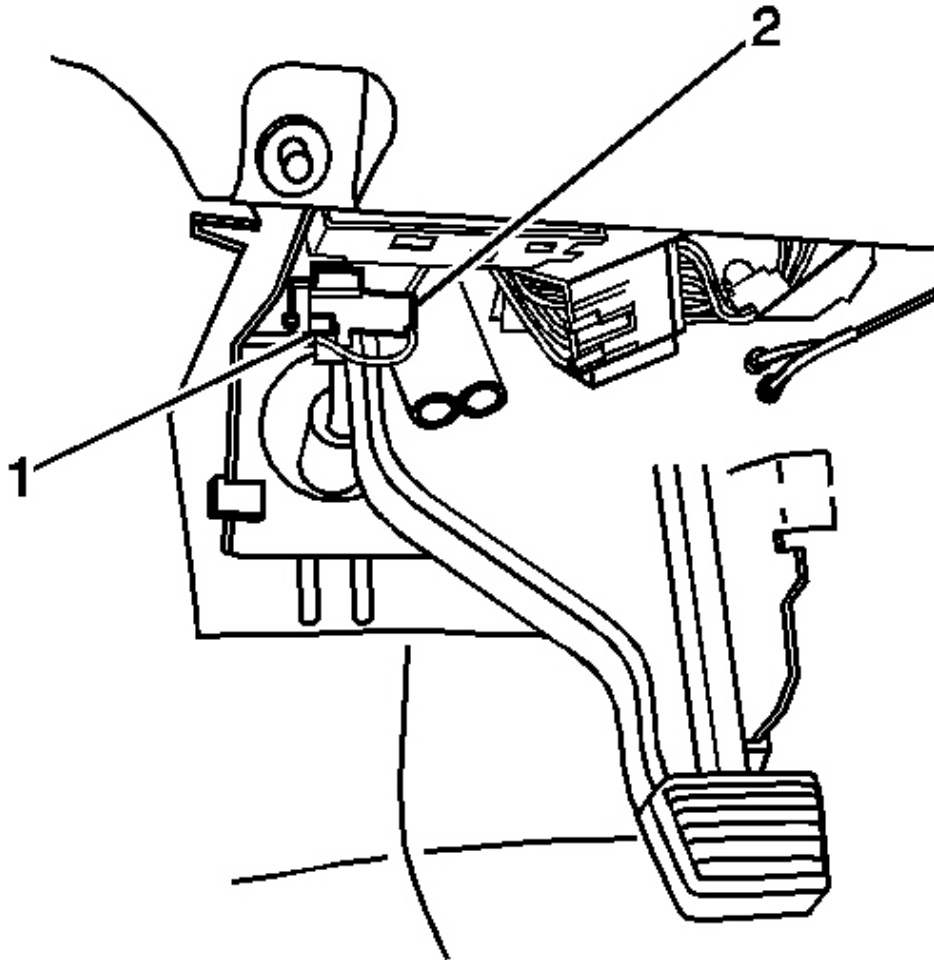

Fig. 11: Connector Position Assurance (CPA), Steering Wheel Module Yellow 4-Way Connector - Zone 3
Courtesy of GENERAL MOTORS CORP.

5. Remove the connector position assurance (CPA) from the (1) steering wheel module yellow 2-way connector (2) located left of the steering column near the knee bolster.
6. Disconnect the (1) steering wheel module yellow 2-way connector (2) located left of the steering column near the knee bolster.

1. Remove the key from the ignition.
2. Connect the (1) steering wheel module yellow 2-way connector (2) located left of the steering column near the knee bolster.
3. Install the CPA to the (1) steering wheel module yellow 2-way connector (2) located left of the steering column near the knee bolster.

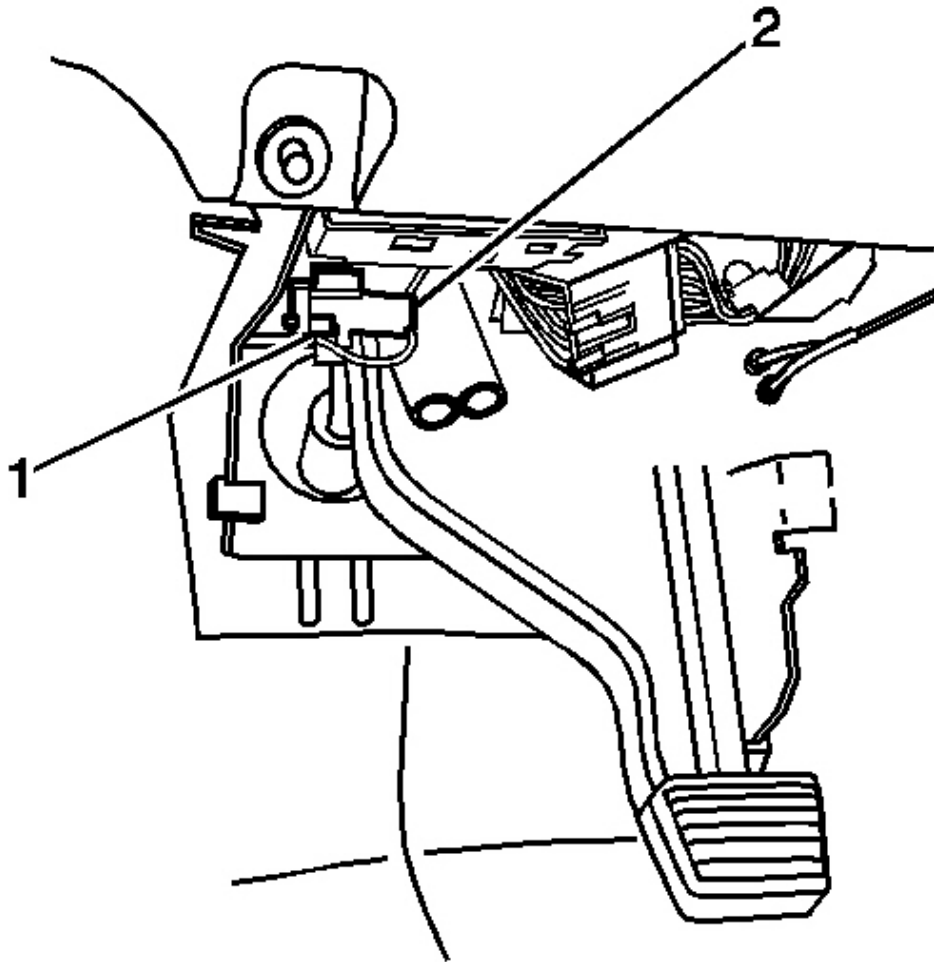

Fig. 12: Connector Position Assurance (CPA), Steering Wheel Module Yellow 4-Way Connector - Zone 3

Courtesy of GENERAL MOTORS CORP.

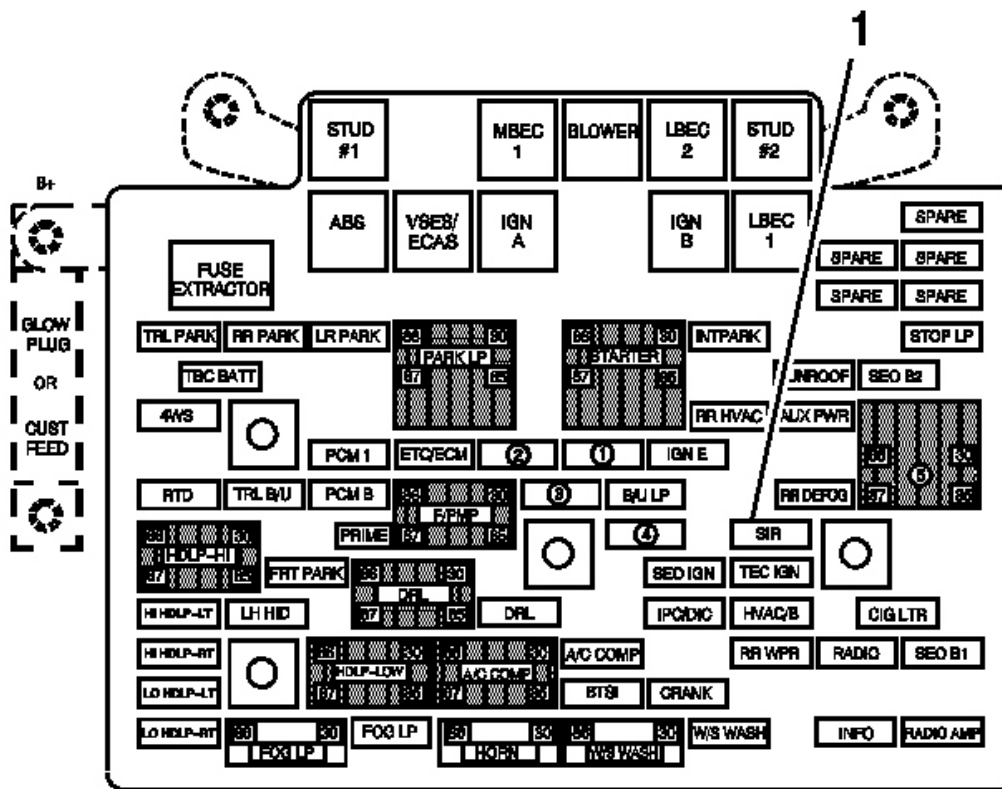

Fig. 13: SIR Fuse & Underhood Fuse Block
 Courtesy of GENERAL MOTORS CORP.

4. Install the SIR fuse (1) into the underhood fuse block.
5. Staying well away from all air bags, turn ON the ignition, with the engine OFF.
 1. The AIR BAG indicator will flash 7 times.
 2. The AIR BAG indicator will then turn OFF.
6. Perform the **Diagnostic System Check - SIR** if the AIR BAG indicator does not operate as described.

SIR DISABLING AND ENABLING ZONE 5

IMPORTANT: Refer to SIR Service Precautions before disabling the SIR system.

Disabling Procedure

1. Turn the steering wheel until the vehicle's wheels are pointing straight ahead.

2. Turn OFF the ignition.
3. Remove the key from the ignition.

IMPORTANT: With the SIR Fuse removed and the ignition ON, the AIR BAG indicator illuminates. This is normal operation and does not indicate an SIR system malfunction.

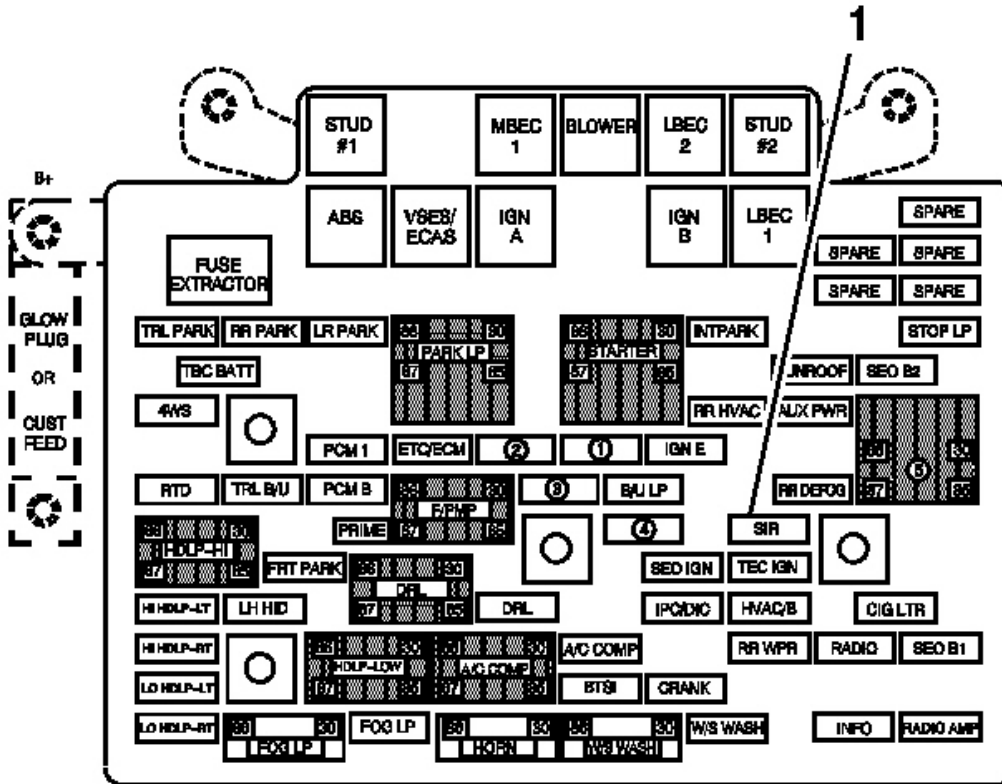

Fig. 14: SIR Fuse & Underhood Fuse Block
 Courtesy of GENERAL MOTORS CORP.

4. Remove the SIR Fuse (1) from the underhood fuse block.

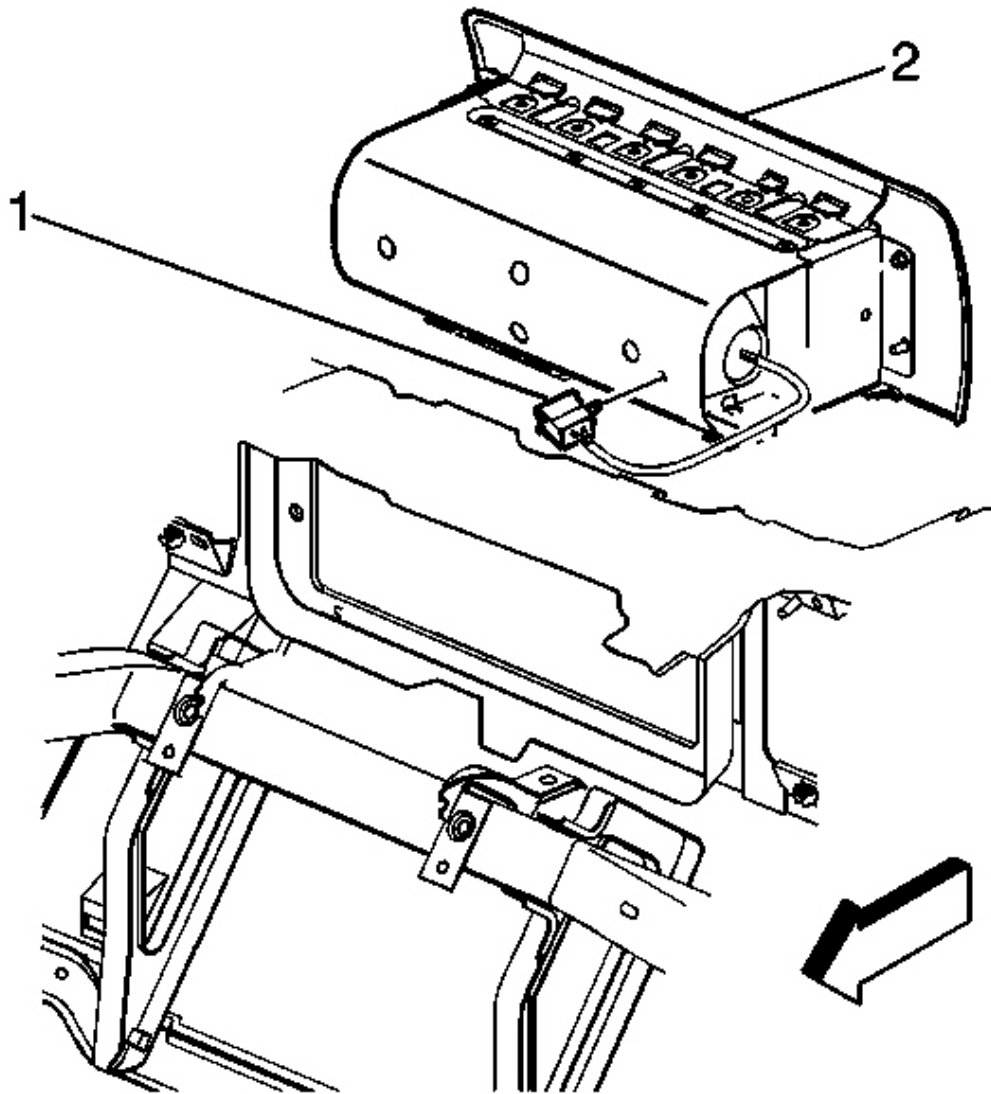

Fig. 15: Connector Position Assurance (CPA) & I/P Module Yellow 4-Way Connector - Zone 5
Courtesy of GENERAL MOTORS CORP.

5. Remove the CPA from the (1) I/P module yellow 2-way connector (2) located behind the I/P module.
6. Disconnect the (1) I/P module yellow 2-way connector (2) located behind the I/P module.

Enabling Procedure

1. Remove the key from the ignition.

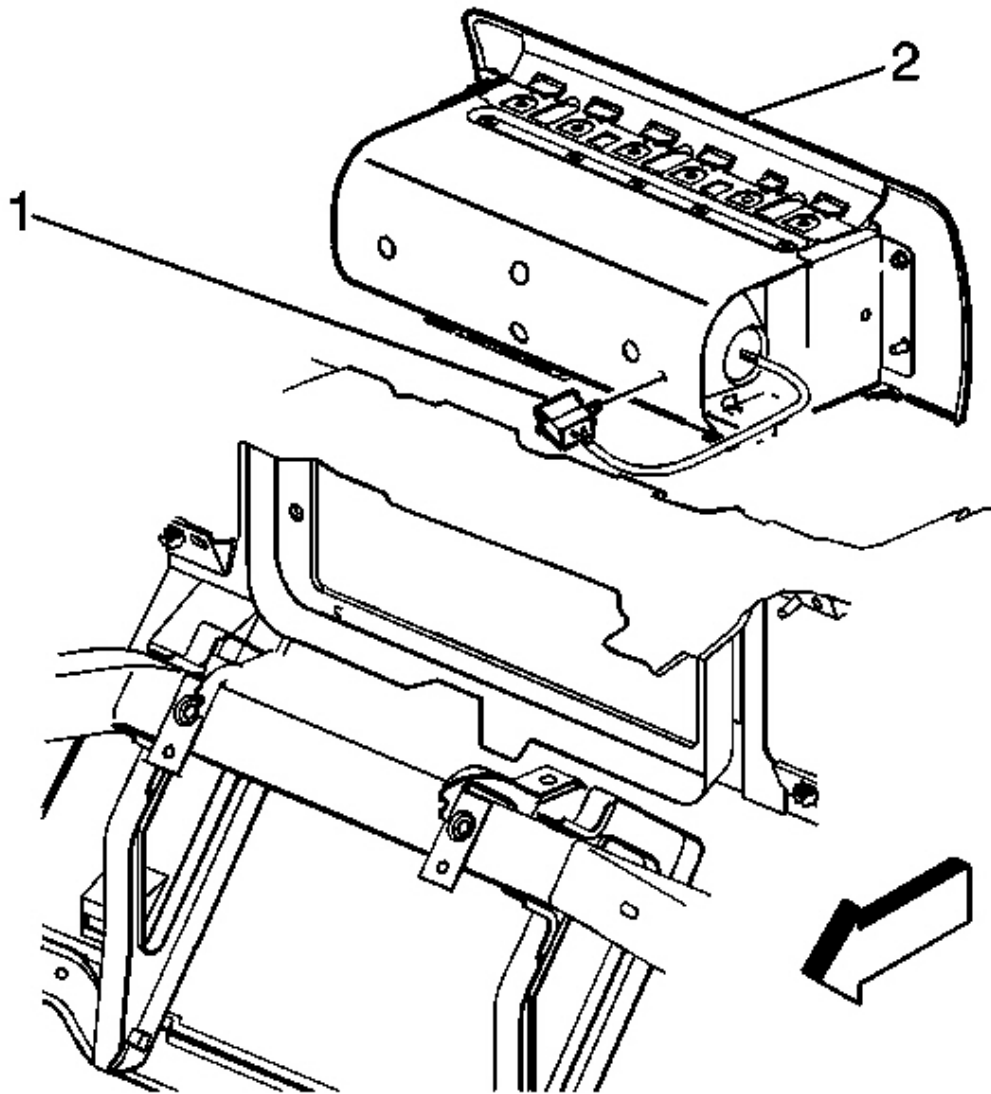

Fig. 16: Connector Position Assurance (CPA) & I/P Module Yellow 4-Way Connector - Zone 5
Courtesy of GENERAL MOTORS CORP.

2. Connect the (1) I/P module yellow 2-way connector (2) located behind the I/P module.
3. Install the CPA to the (1) I/P module yellow 2-way connector (2) located behind the I/P module.

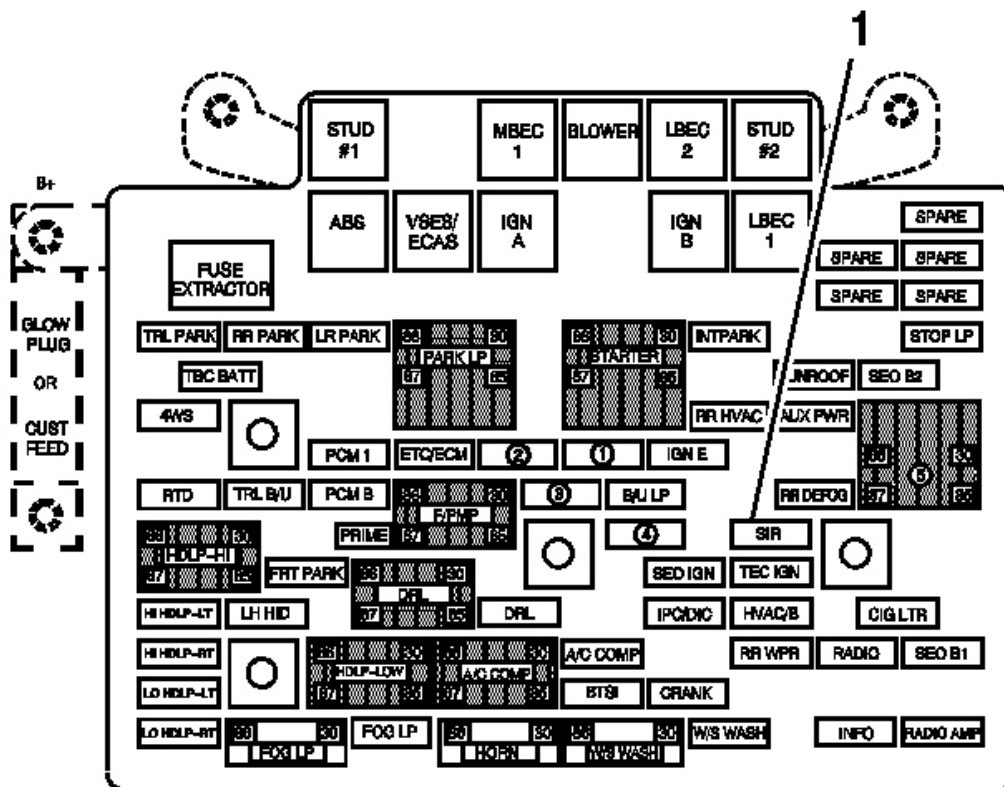

Fig. 17: SIR Fuse & Underhood Fuse Block
 Courtesy of GENERAL MOTORS CORP.

4. Install the SIR Fuse (1) into the underhood fuse block.
5. Staying well away from all air bags, turn ON the ignition, with the engine OFF.
 1. The AIR BAG indicator will flash 7 times.
 2. The AIR BAG indicator will then turn OFF.
6. Perform the **Diagnostic System Check - SIR** if the AIR BAG indicator does not operate as described.

SIR DISABLING AND ENABLING ZONE 7

IMPORTANT: Refer to SIR Service Precautions before disabling the SIR system.

Disabling Procedure

1. Turn the steering wheel until the vehicle's wheels are pointing straight ahead.

2. Turn OFF the ignition.
3. Remove the key from the ignition.

IMPORTANT: With the SIR Fuse removed and the ignition ON, the AIR BAG indicator illuminates. This is normal operation and does not indicate an SIR system malfunction.

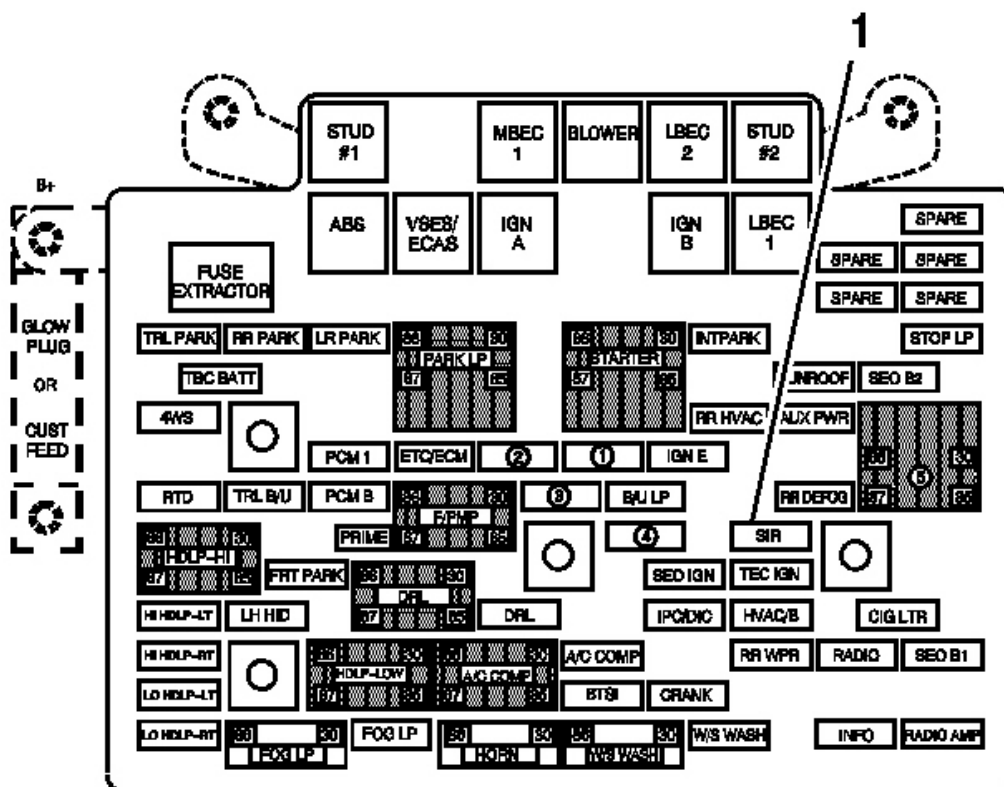

Fig. 18: SIR Fuse & Underhood Fuse Block
 Courtesy of GENERAL MOTORS CORP.

4. Remove the SIR Fuse (1) from the underhood fuse block.

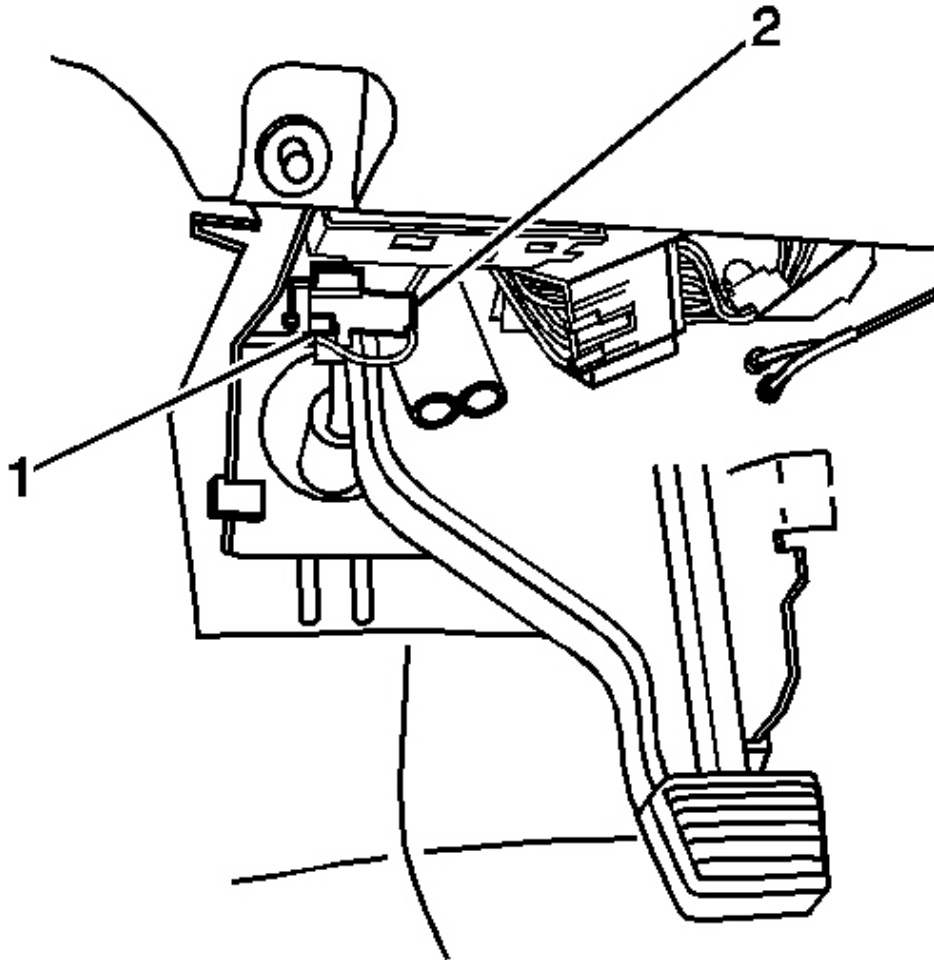

Fig. 19: Connector Position Assurance (CPA) & Steering Wheel Module Yellow 4-Way Connector - Zone 7
Courtesy of GENERAL MOTORS CORP.

5. Remove the connector position assurance (CPA) from the (1) steering wheel module yellow 2-way connector (2) located left of the steering column near the knee bolster.
6. Disconnect the (1) steering wheel module yellow 2-way connector (2) located left of the steering column near the knee bolster.

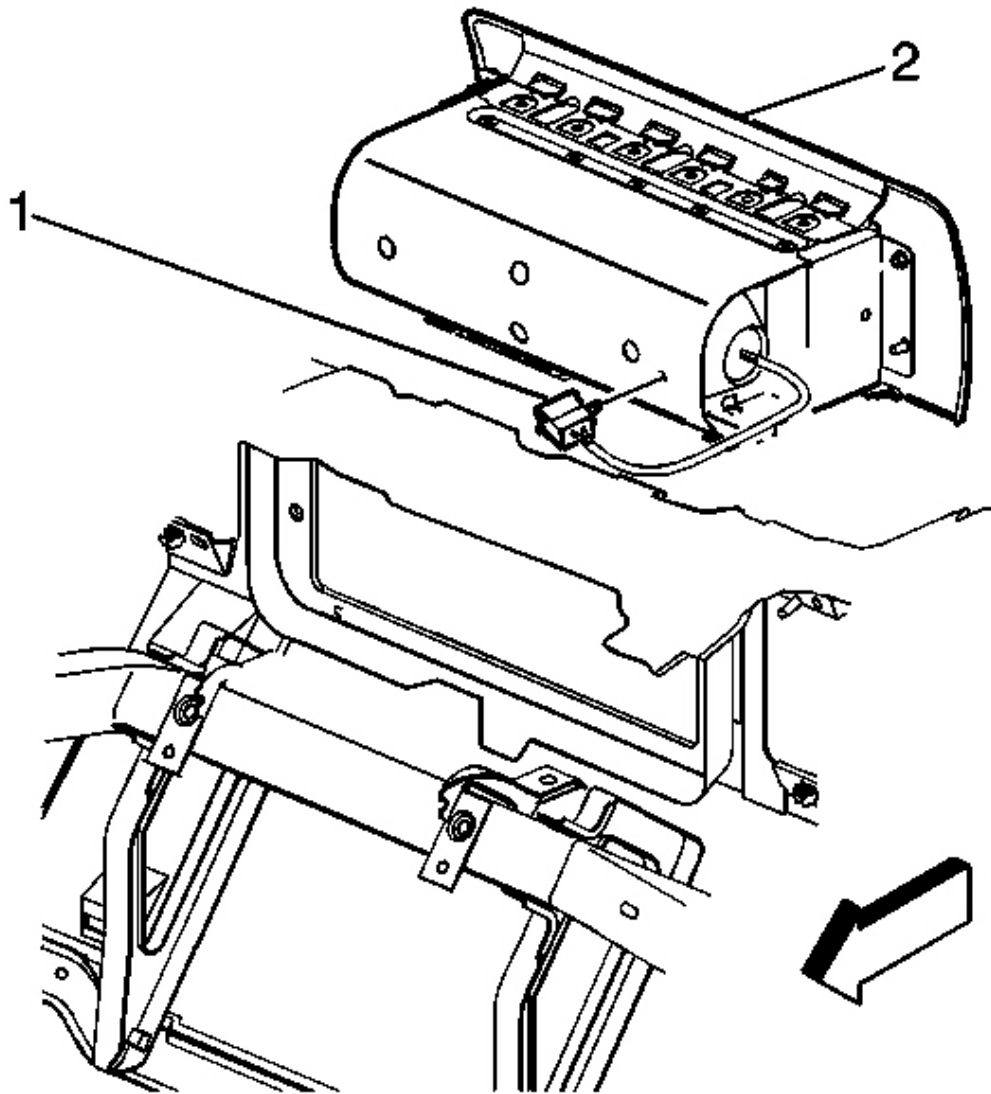

Fig. 20: Connector Position Assurance (CPA) & I/P Module Yellow 4-Way Connector - Zone 5
Courtesy of GENERAL MOTORS CORP.

7. Remove the CPA from the (1) I/P module yellow 2-way connector (2) located behind the I/P module.
8. Disconnect the (1) I/P module yellow 2-way connector (2) located behind the I/P module.

Enabling Procedure

1. Remove the key from the ignition.

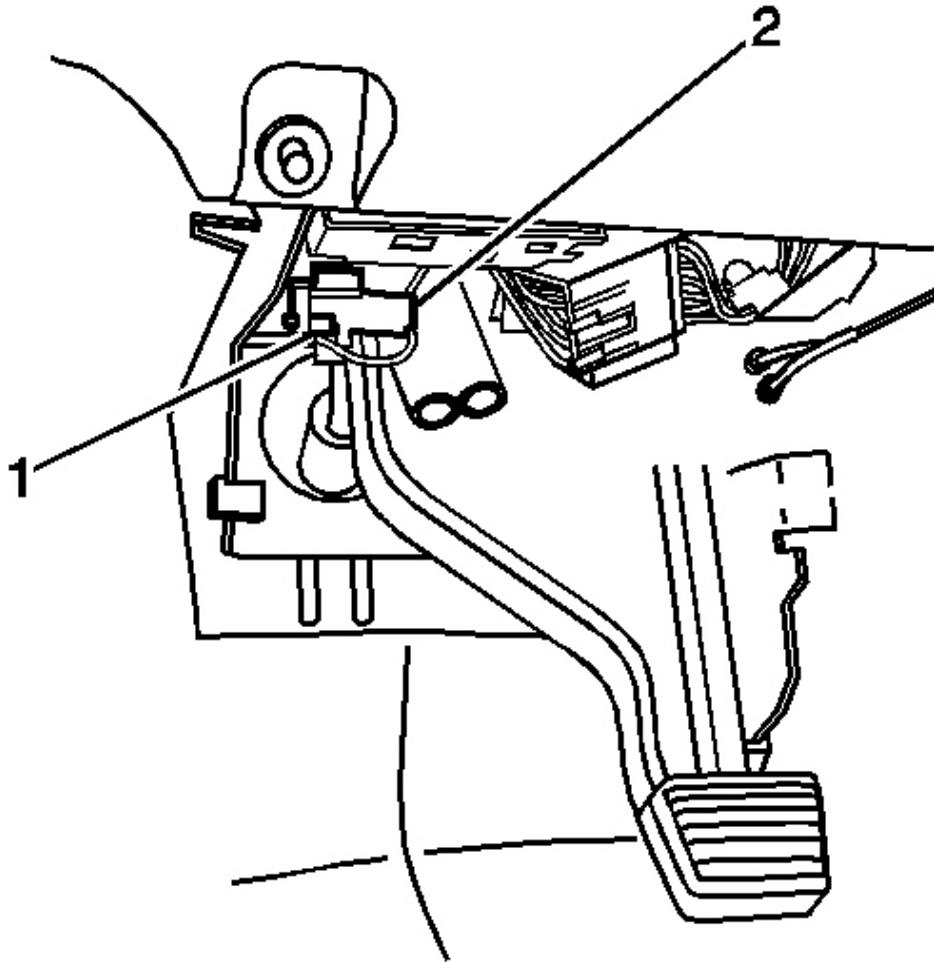

Fig. 21: Connector Position Assurance (CPA) & Steering Wheel Module Yellow 4-Way Connector - Zone 7

Courtesy of GENERAL MOTORS CORP.

2. Connect the (1) steering wheel module yellow 2-way connector (2) located left of the steering column near the knee bolster.
3. Install the CPA to the (1) steering wheel module yellow 2-way connector (2) located left of the steering

column near the knee bolster.

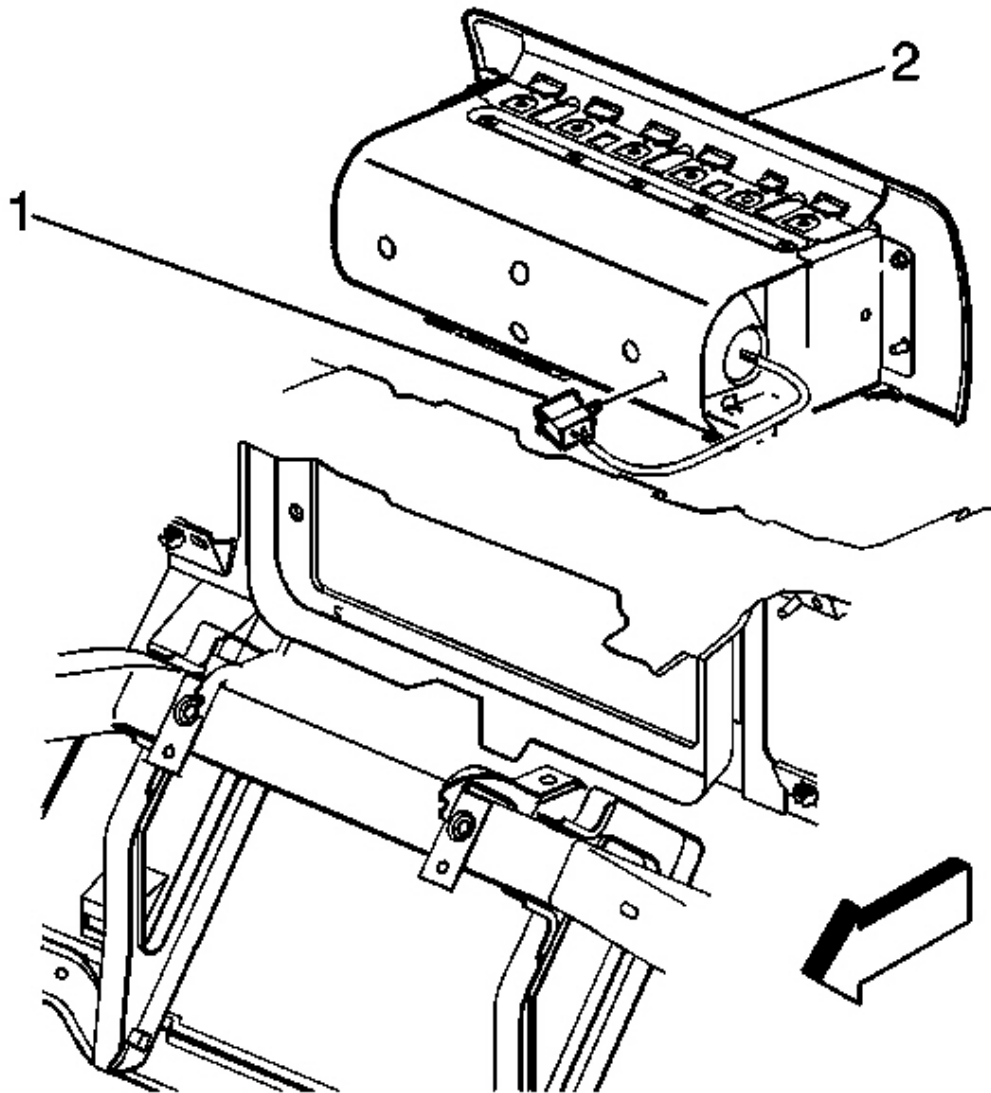

Fig. 22: Connector Position Assurance (CPA) & I/P Module Yellow 4-Way Connector - Zone 5
Courtesy of GENERAL MOTORS CORP.

4. Connect the (1) I/P module yellow 2-way connector (2) located behind the I/P module.
5. Install the CPA (1) to the I/P module yellow 2-way connector (2) located behind the I/P module.

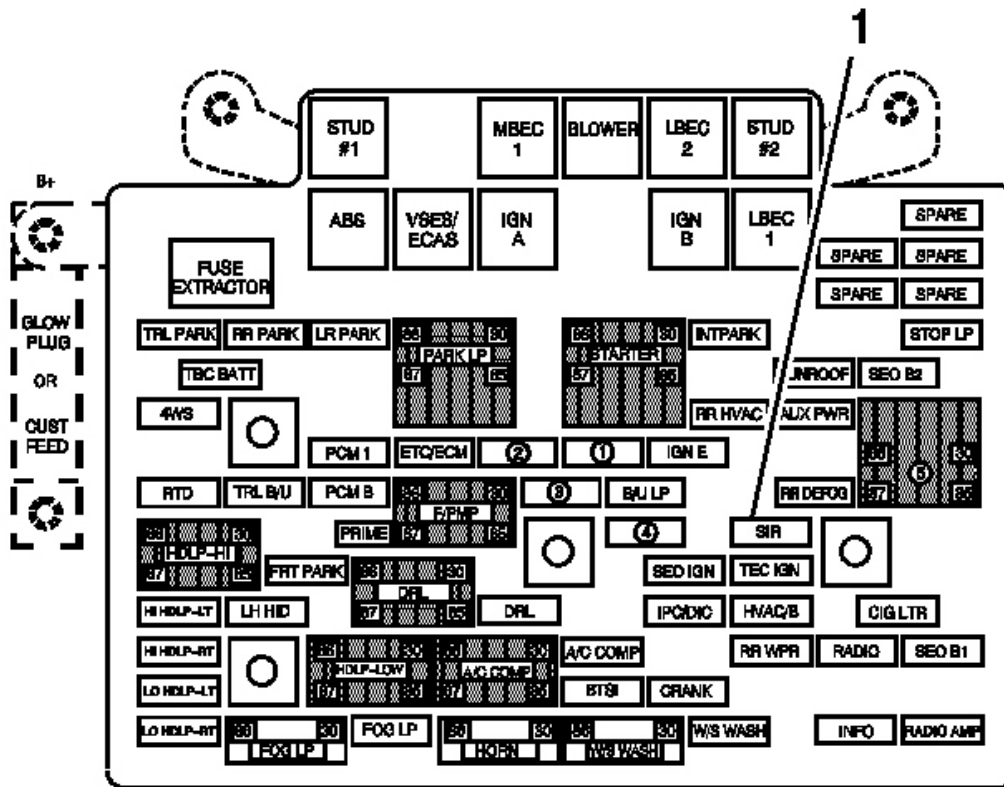

Fig. 23: SIR Fuse & Underhood Fuse Block
 Courtesy of GENERAL MOTORS CORP.

6. Install the SIR Fuse (1) into the underhood fuse block.
7. Staying well away from all air bags, turn ON the ignition, with the engine OFF.
 1. The AIR BAG indicator will flash 7 times.
 2. The AIR BAG indicator will then turn OFF.
8. Perform the **Diagnostic System Check - SIR** if the AIR BAG indicator does not operate as described.

INFLATABLE RESTRAINT FRONT END SENSOR REPLACEMENT

CAUTION: Refer to **SIR Caution** in Cautions and Notices.

Removal Procedure

1. Disable the SIR system. Refer to sir disabling and enabling zones. Refer to **SIR Disabling and Enabling Zones** .
2. Remove the engine protection shield, if equipped. Refer to **Engine Protection Shield Replacement** in Frame and Underbody.

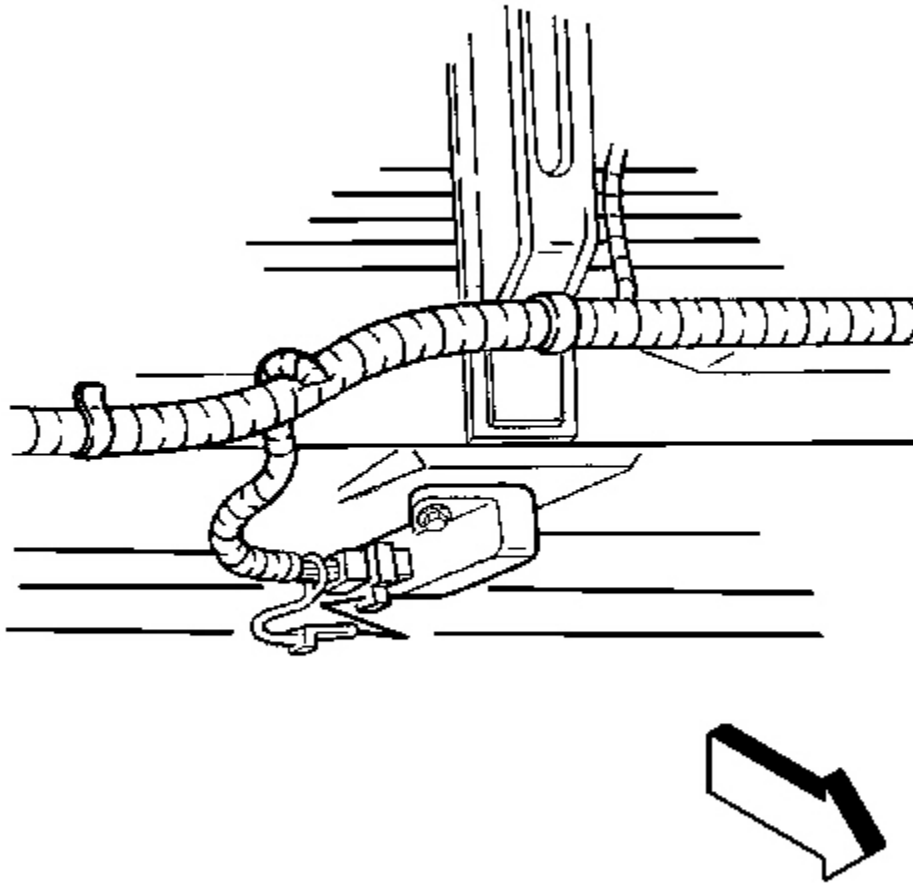

Fig. 24: CPA & Inflation Restraint Front End Discriminator Sensor Harness Connector
Courtesy of GENERAL MOTORS CORP.

3. Remove the connector position assurance (CPA) from the inflatable restraint front end discriminator sensor harness connector.

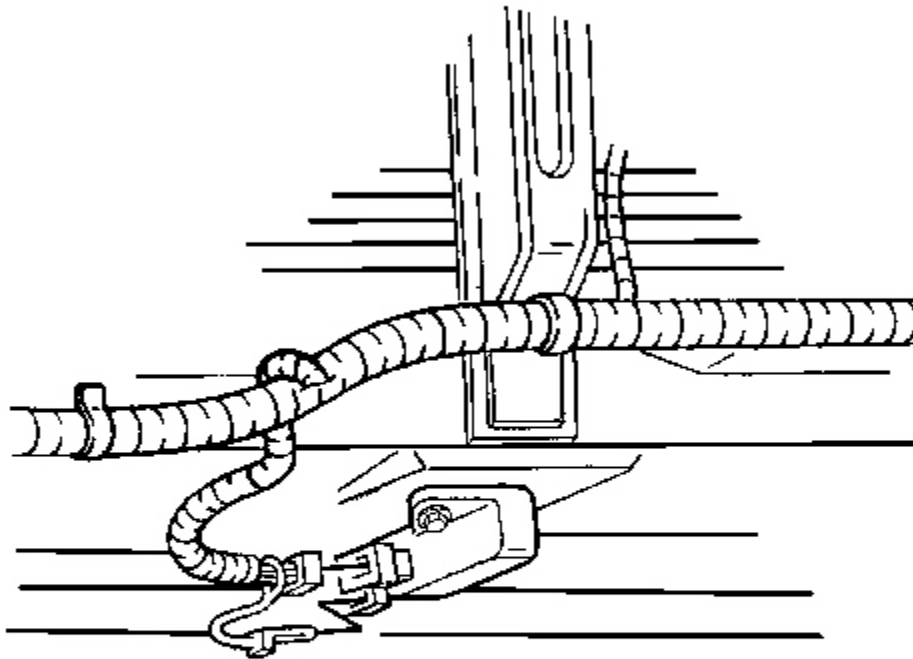

Fig. 25: Inflatable Restraint Front End Discriminating Sensor Harness Connector
Courtesy of GENERAL MOTORS CORP.

4. Disconnect the inflatable restraint front end discriminating sensor harness connector from the sensor.

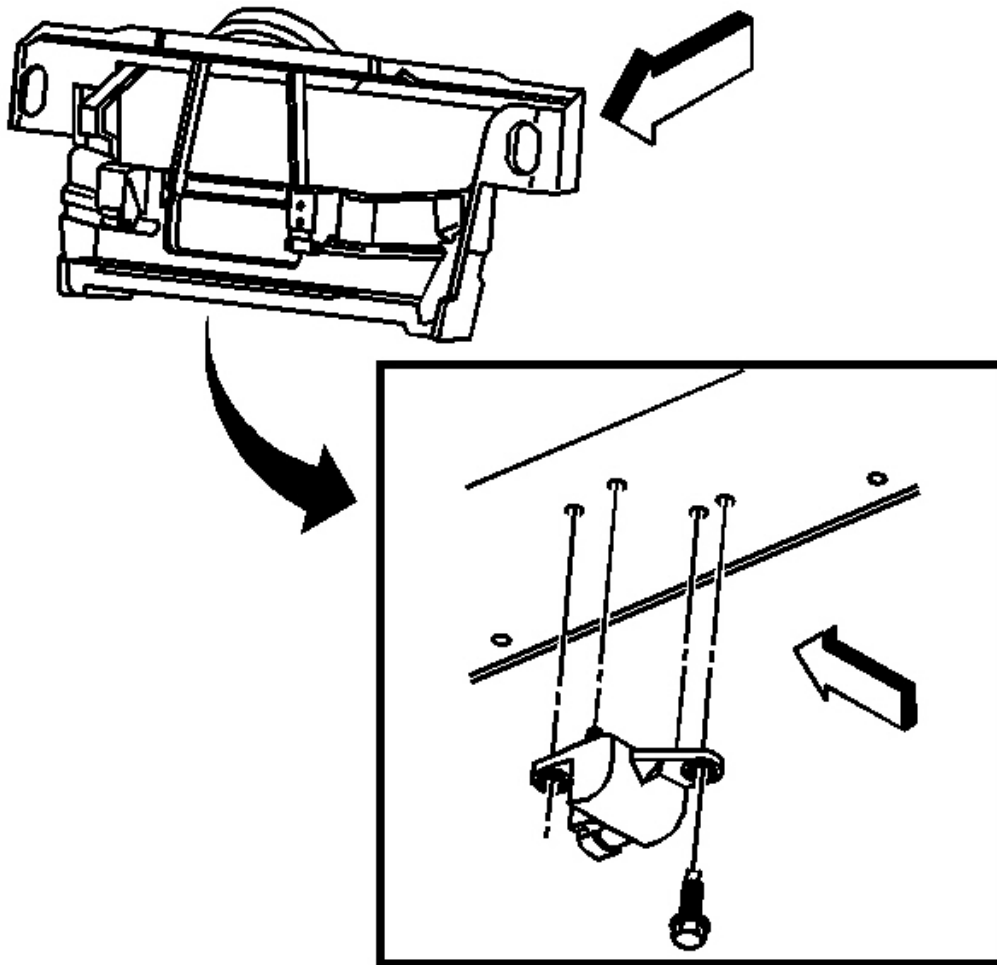

Fig. 26: CPA & EFS Connectors Located On The Frame Crossmember
Courtesy of GENERAL MOTORS CORP.

5. Remove the mounting fasteners.
6. Remove the inflatable restraint front end discriminating sensor from the vehicle.

IMPORTANT: The following procedure should be utilized in the event that the sensor mounting holes or fasteners are damaged to the extent that the sensor may no longer be properly mounted.

7. Perform the following steps in order to complete the fastener repair:
 1. Remove and discard the improperly installed fastener.

2. Chisel off the damaged weld nut.
3. Condition the front end lower tie surface where the new weld nut is to be installed.
4. Install the new weld nut GM P/N 11514034 or equivalent into position.
5. Migweld the new weld nut to the front end lower tie surface in the correct
6. Use the new fastener GM P/N 11514034 or equivalent.

Installation Procedure

1. Install the inflatable restraint front end discriminating sensor to the front end lower tie surface.

NOTE: Refer to Fastener Notice in **Cautions and Notices**.

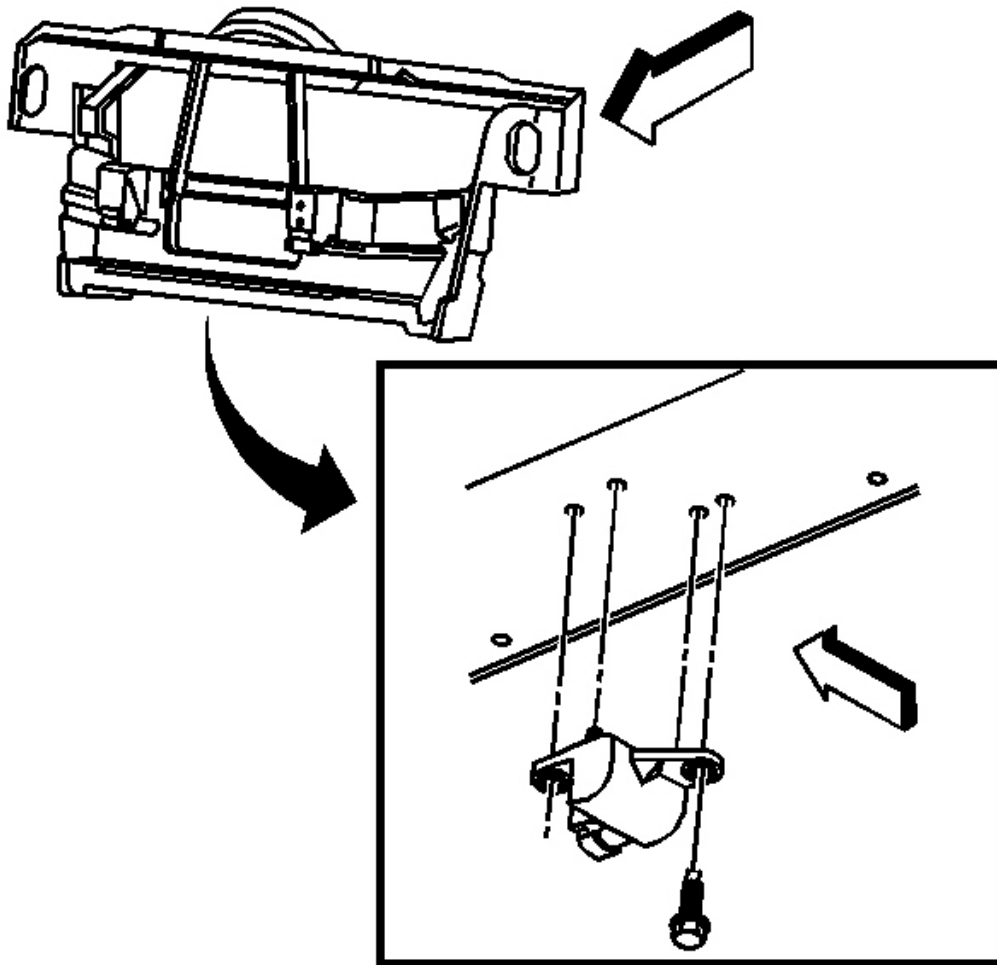

Fig. 27: CPA & EFS Connectors Located On The Frame Crossmember
Courtesy of GENERAL MOTORS CORP.

2. Install the inflatable restraint front end discriminating sensor mounting fasteners.

Tighten: Tighten the screws to 10 N.m (89 lb in).

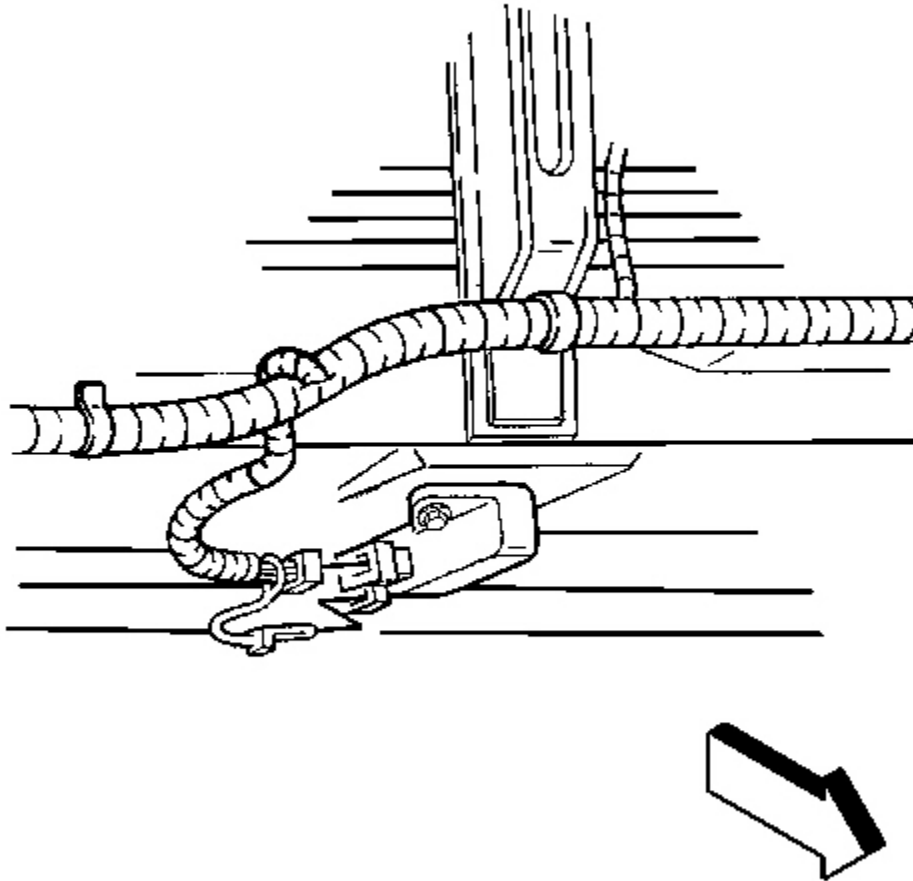

Fig. 28: Inflatable Restraint Front End Discriminating Sensor Harness Connector
Courtesy of GENERAL MOTORS CORP.

3. Connect the inflatable restraint front end discriminating harness connector to the sensor.
4. Install the connector position assurance (CPA) to the inflatable restraint front end discriminating sensor harness connector.
5. Install the engine protection shield, if equipped. Refer to **Engine Protection Shield Replacement** in Frame and Underbody.
6. Enable the SIR system. Refer to **SIR Disabling and Enabling Zones** .

INFLATABLE RESTRAINT SENSING AND DIAGNOSTIC MODULE REPLACEMENT

CAUTION: Do not strike or jolt the inflatable restraint sensing and diagnostic module

(SDM). Before applying power to the SDM, make sure that it is securely fastened with the arrow facing toward the front of the vehicle. Failure to observe the correct installation procedure could cause SIR deployment, personal injury, or unnecessary SIR system repairs.

CAUTION: Refer to SIR Caution in Cautions and Notices.

Removal Procedure

1. Disable the SIR system. Refer to SIR Disabling and Enabling Zones .

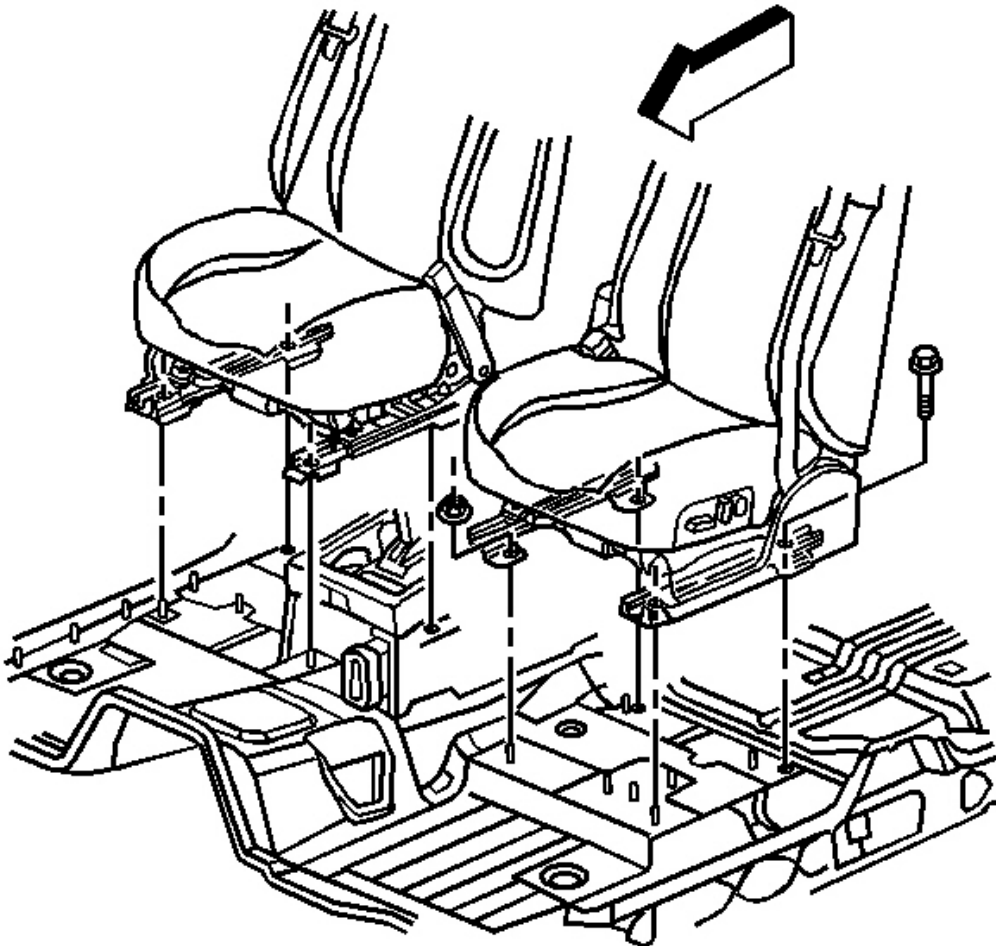

Fig. 29: Removing Drivers Seat
Courtesy of GENERAL MOTORS CORP.

2. Remove the drivers seat. Refer to **Seat Replacement - Front Bucket** in Seats.
3. Remove the driver side door sill plate. Refer to **Door Sill Plate Replacement - Front** in Interior Trim.
4. Fold back the carpet to access the inflatable restraint sensing and diagnostic module (SDM).

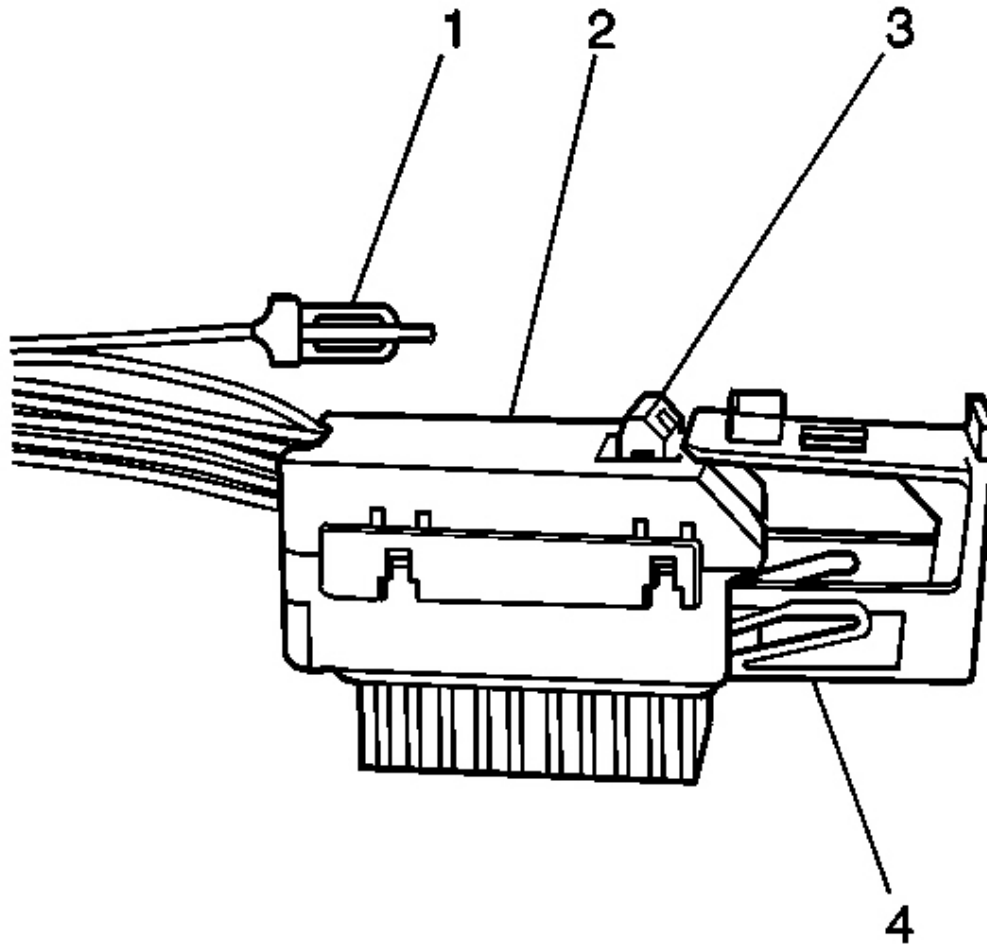

Fig. 30: Connector Position Assurance (CPA)
Courtesy of GENERAL MOTORS CORP.

5. Remove the connector position assurance (CPA) (1) from the inflatable restraint sensing and diagnostic module (SDM) wiring harness connector (2).

6. Push down the flex lock button (3) and slide the connector locking cover (4) to the open position.

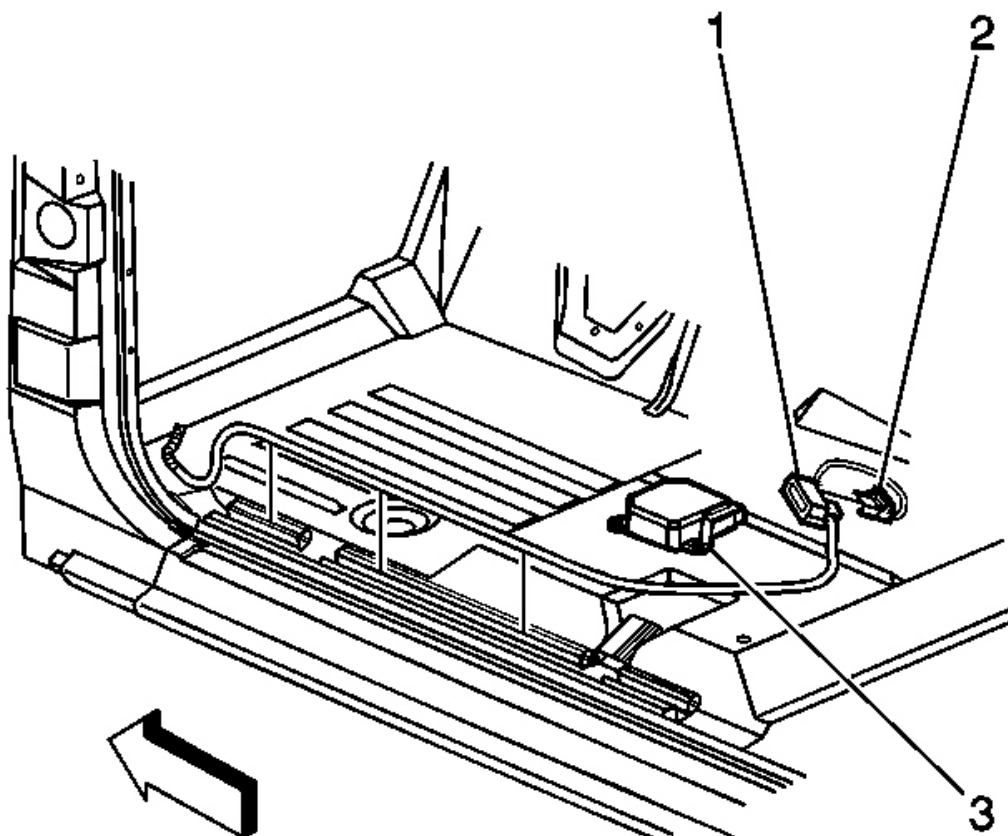

Fig. 31: SDM Wiring Harness Connector & SDM
Courtesy of GENERAL MOTORS CORP.

7. Disconnect the SDM wiring harness connector (1) from the SDM (3).

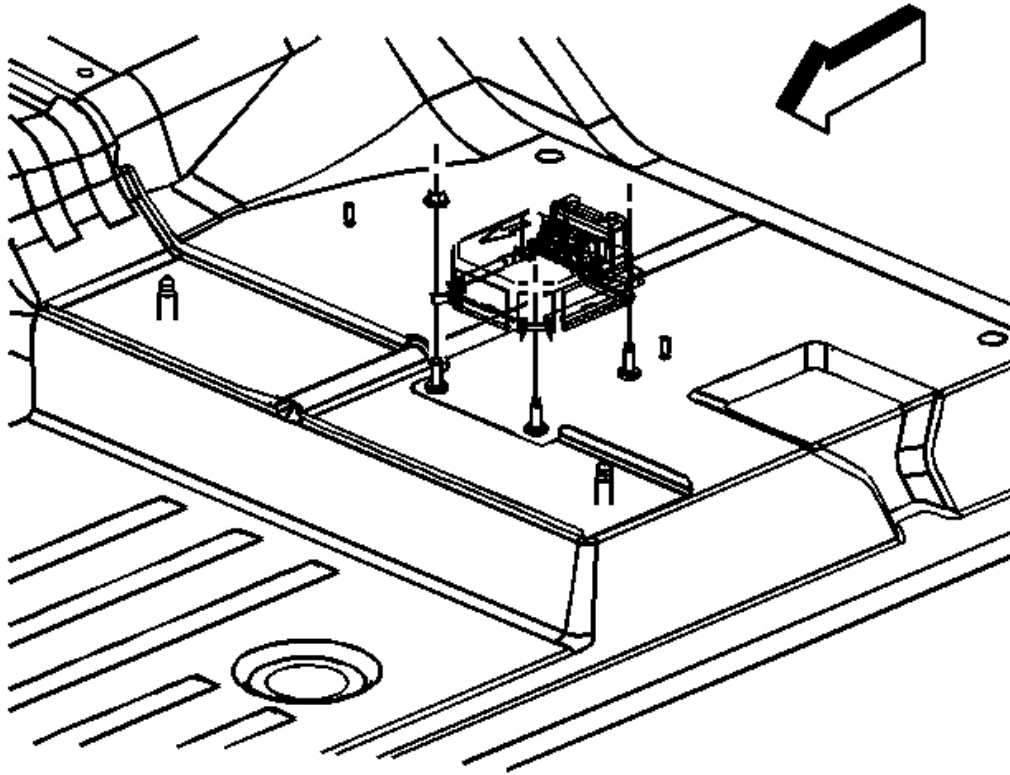

Fig. 32: Identifying SDM
Courtesy of GENERAL MOTORS CORP.

8. Remove the SDM mounting fasteners.
9. Remove the SDM from the vehicle.

IMPORTANT: The following repair procedures should only be used in the event that the inflatable restraint sensing and diagnostic module (SDM) mounting studs and/or fasteners are damaged to the extent that the SDM may no longer be properly mounted.

10. Repair the fasteners using the following procedure:
 1. Remove the stripped nut and discard the nut.
 2. Drill out the weld spots to the weld stud from the floor pan side, then remove and discard the stud.
 3. Condition the floor panel attaching surface where the new stud is to be installed.
 4. Install new weld stud GM P/N 115115602 and clamp the weld stud.
 5. Migweld the stud at the drilled holes from above or below the floor pan, as required.

6. Apply body sealer GM P/N 9984248 around any exposed openings.
7. Install a new fastener GM P/N 11515933.

Installation Procedure

1. Remove any dirt, grease, or other impurities from the mounting surface.

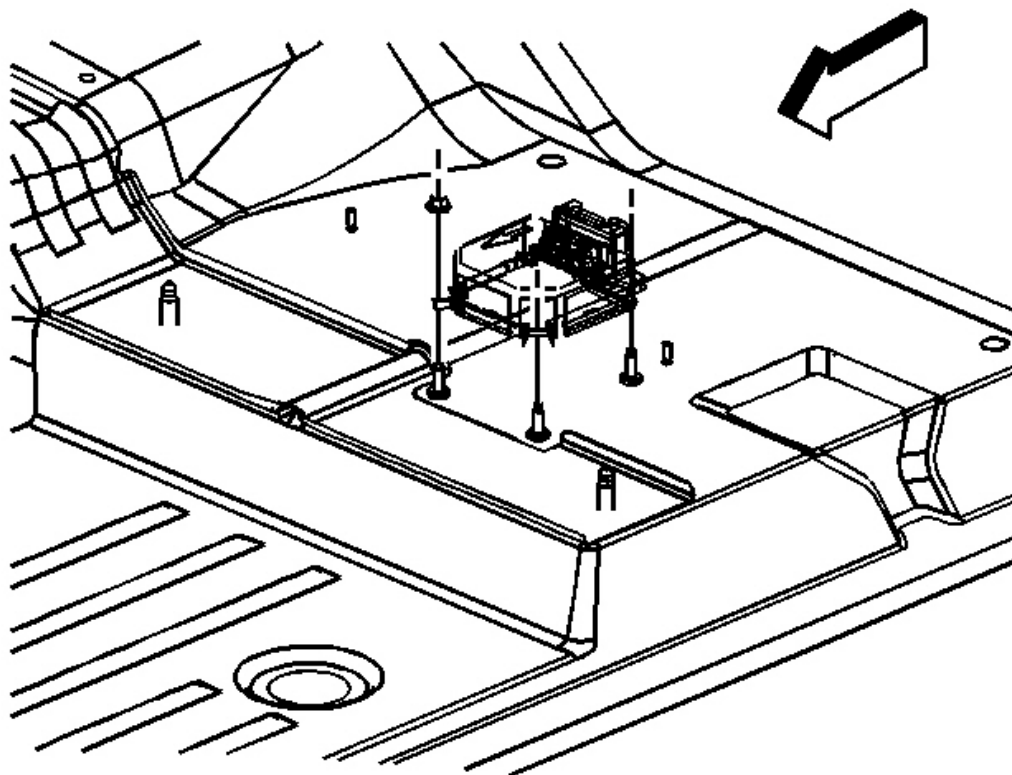

Fig. 33: Identifying SDM
Courtesy of GENERAL MOTORS CORP.

2. Install the SDM (3) horizontally to the vehicle.
3. Point the arrow on the SDM toward the front of the vehicle.

NOTE: Refer to Fastener Notice in Cautions and Notices.

4. Install the SDM mounting fasteners.

Tighten: Tighten fasteners to 10 N.m (89 lb in).

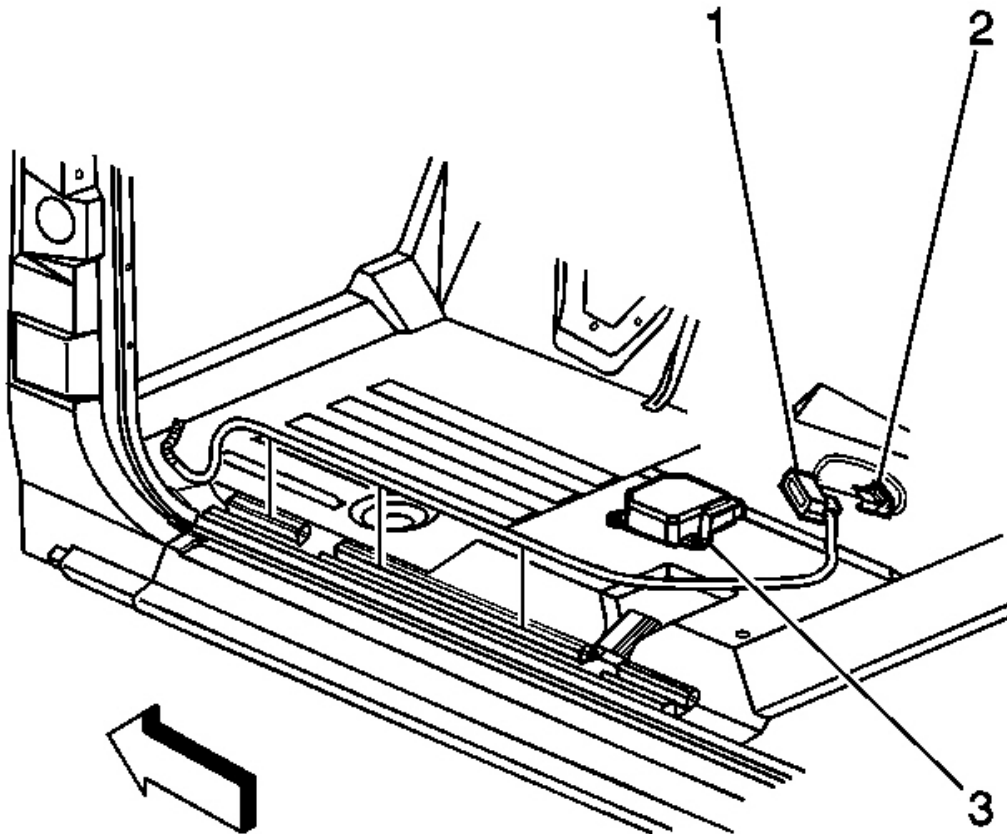

Fig. 34: SDM Wiring Harness Connector & SDM
Courtesy of GENERAL MOTORS CORP.

5. Connect the SDM wiring harness connector (1) to the SDM.

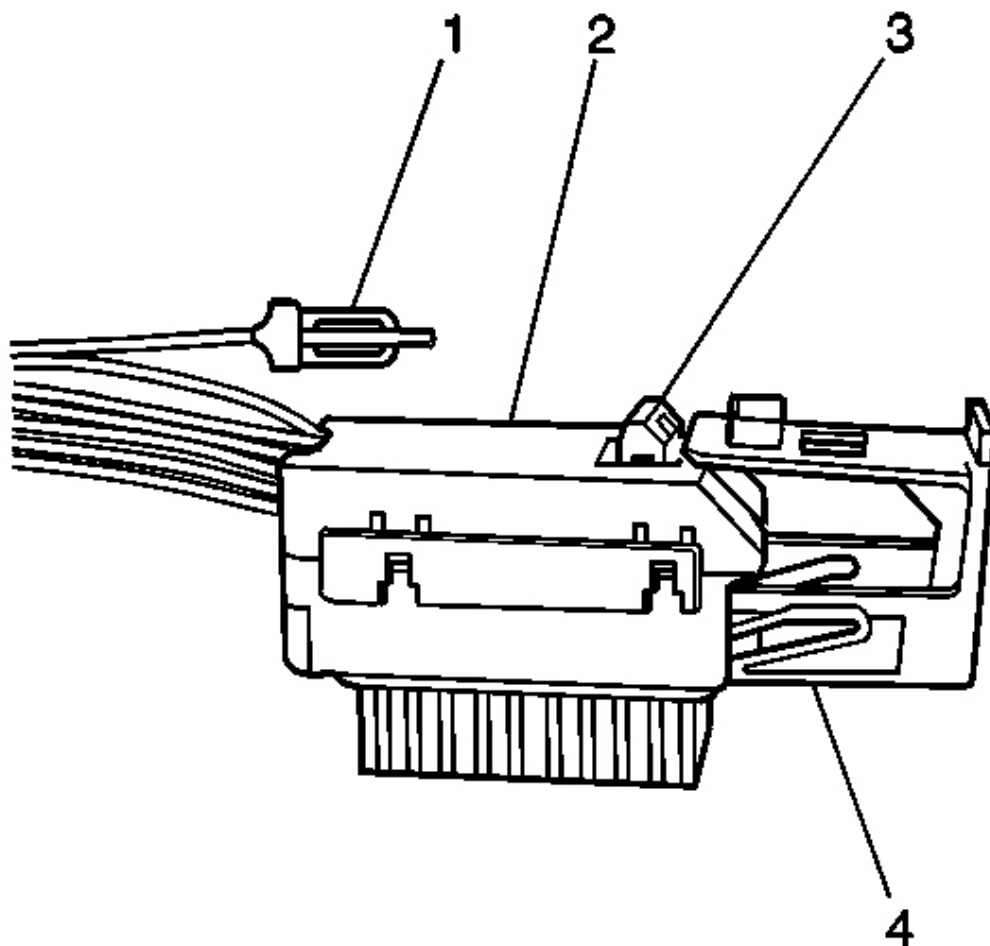

Fig. 35: Connector Position Assurance (CPA)
Courtesy of GENERAL MOTORS CORP.

6. Push down the flex lock button (3) and slide the connector locking cover (4) to the close position.
7. Install the connector position assurance (CPA) (1) to the inflatable restraint sensing and diagnostic module (SDM) wiring harness connector (2).
8. Position the carpet to cover the inflatable restraint sensing and diagnostic module (SDM).
9. Install the door sill plate. Refer to **Door Sill Plate Replacement - Front** in Interior Trim.
10. Install the driver seat. Refer to **Seat Replacement - Front Bucket** in Seats.

IMPORTANT: The AIR BAG indicator may remain ON after the SDM has been replaced.

DTC B1001 may set requiring the SDM part number to be set in multiple modules. If the indicator remains ON after enabling the SIR system, perform the diagnostic system check and follow the steps thoroughly to ensure that the SDM is set properly.

11. Enable the SIR system. Refer to **SIR Disabling and Enabling Zones** .

INFLATABLE RESTRAINT STEERING WHEEL MODULE REPLACEMENT

CAUTION: Refer to SIR Inflator Module Handling and Storage Caution in Cautions and Notices.

CAUTION: Refer to SIR Caution in Cautions and Notices.

Removal Procedure

1. Disable the inflatable restraint steering wheel module. Refer to **SIR Disabling and Enabling Zone 3** .

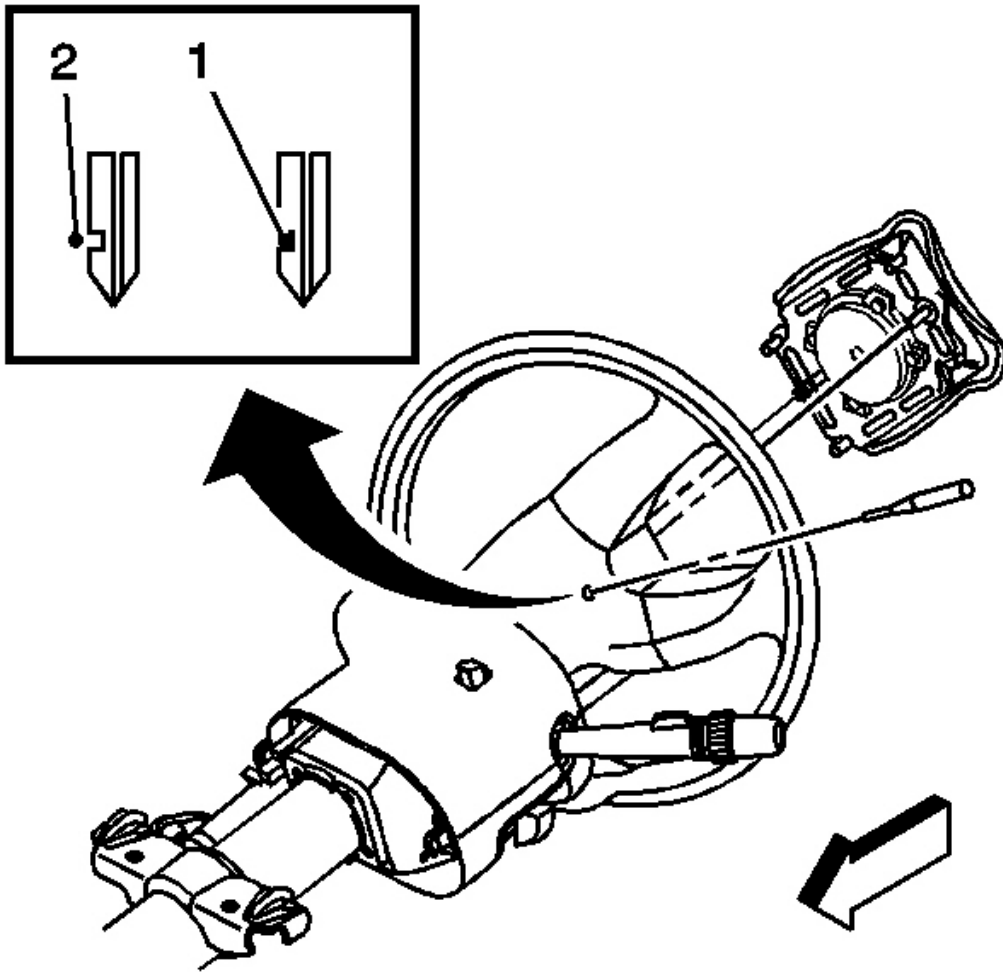

Fig. 36: Steering Column Leaf Spring Fasteners
Courtesy of GENERAL MOTORS CORP.

2. Using a blunt-ended tool, push the leaf spring fasteners (2) inward through the access holes. The access holes are located on both sides of the steering wheel shroud.

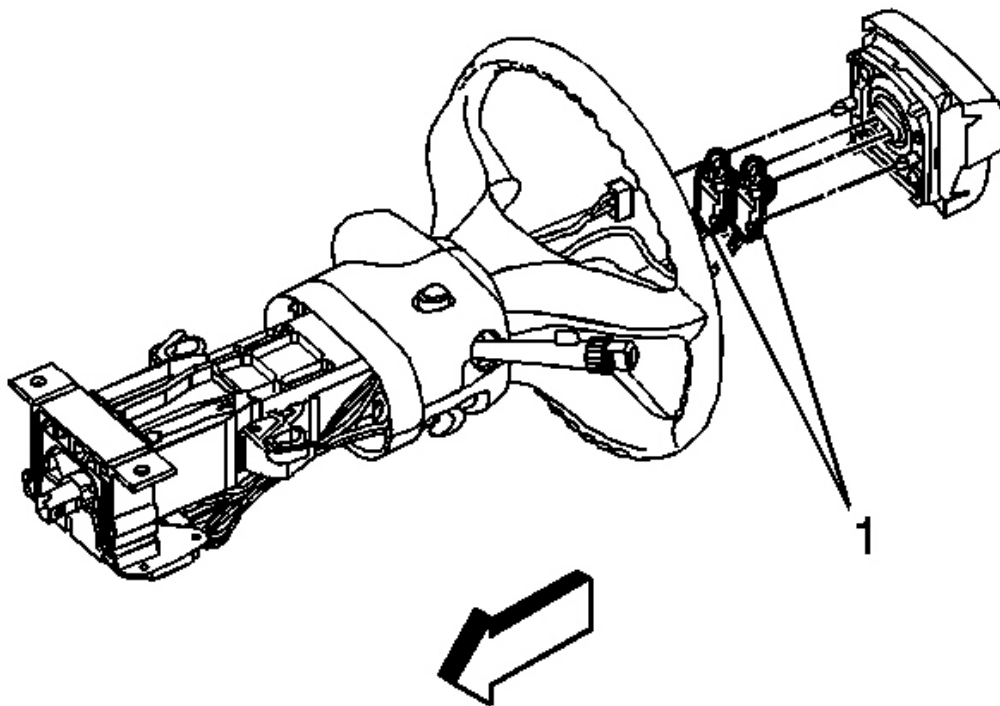

Fig. 37: Electrical Connectors & Inflatable Restraint Steering Wheel Module
Courtesy of GENERAL MOTORS CORP.

3. Lift and partially remove the inflatable restraint steering wheel module from the steering wheel in order to expose the electrical connectors (1).
4. Disconnect the connector-position assurance (CPA) retainers from the electrical connectors.
5. Disconnect the electrical connectors from the inflatable restraint steering wheel module.

IMPORTANT: Do not attempt to repair the inflatable restraint steering wheel module. The inflatable restraint steering wheel module is replaced only as an assembly.

6. Remove the inflatable restraint module from the steering wheel.
7. Fully deploy the module before disposal. If the module was replaced under warranty, fully deploy and dispose of the module after the required retention period. Refer to **Inflator Module Handling and Scrapping** .

1. Position the inflatable restraint module to the steering wheel.
2. Connect the electrical connectors (1) to the inflatable restraint steering wheel module.

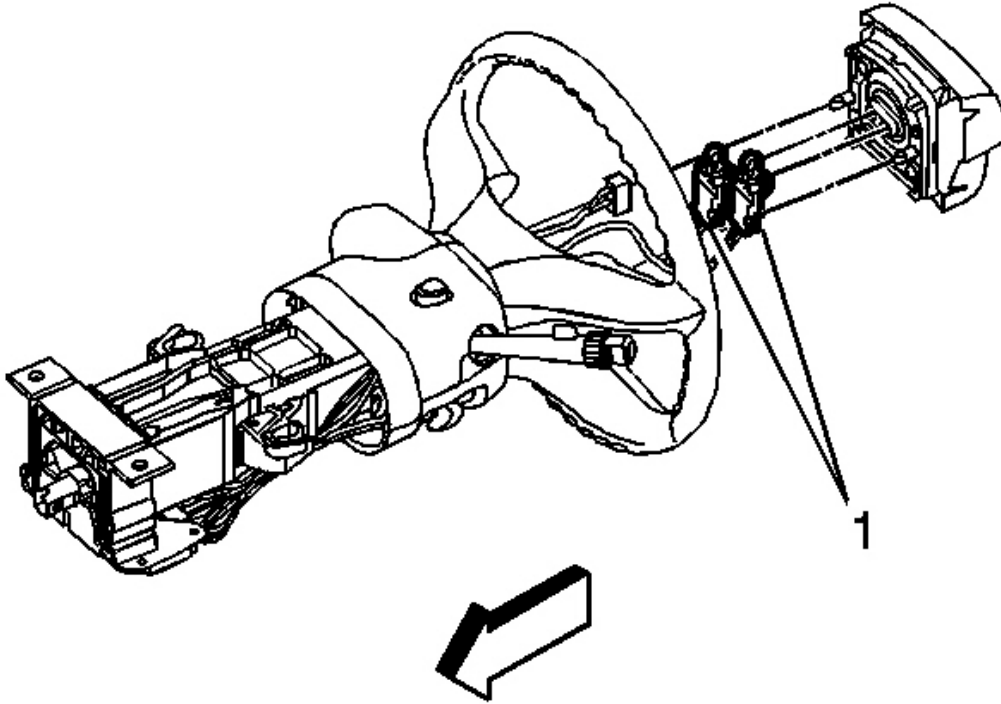

Fig. 38: Electrical Connectors & Inflatable Restraint Steering Wheel Module
Courtesy of GENERAL MOTORS CORP.

3. Connect the CPA retainers into the electrical connectors. Seat and lock the connections.

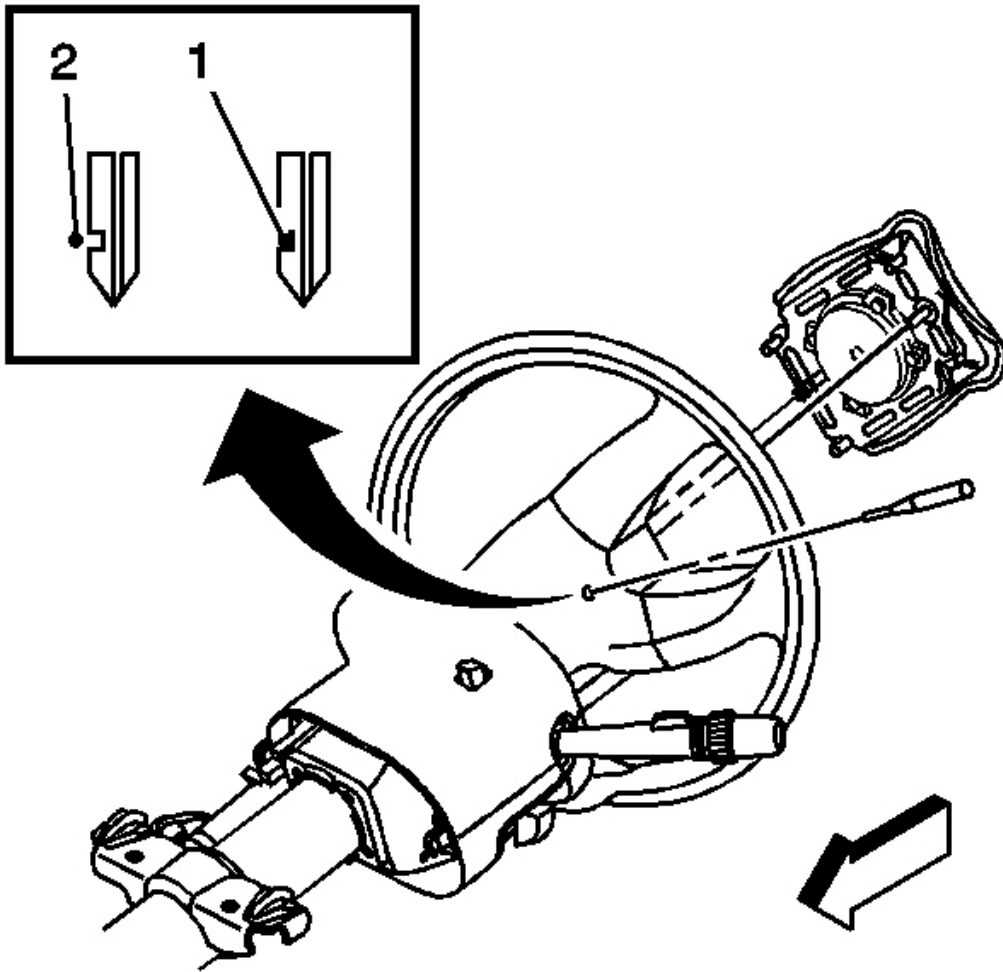

Fig. 39: Steering Column Leaf Spring Fasteners
Courtesy of GENERAL MOTORS CORP.

4. Position the alignment posts of the inflatable restraint module to the holes that are located on the steering wheel housing.
5. Push the inflatable restraint module into the steering wheel in order to engage and in order to latch the 2 leaf spring fasteners (1).
6. After installation, pull the sides of the inflatable restraint module in order to ensure that both leaf spring fasteners are engaged.
7. Enable the inflatable restraint steering wheel module. Refer to **SIR Disabling and Enabling Zone 3**.

Tools Required

J 42640 Steering Column Anti Rotation Pin

Removal Procedure

CAUTION: Refer to SIR Caution in Cautions and Notices.

1. Disable the SIR System. Refer to SIR Disabling and Enabling Zone 3.

NOTE: The wheels of the vehicle must be straight ahead and the steering column in the LOCK position before disconnecting the steering column or intermediate shaft from the steering gear. Failure to do so will cause the SIR coil assembly to become uncentered, which may cause damage to the coil assembly.

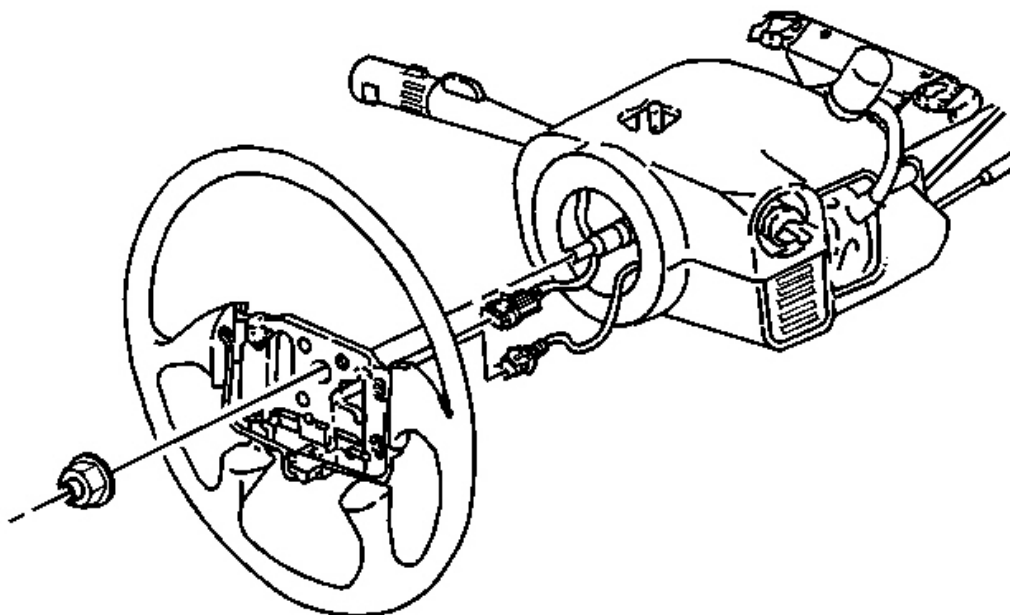

Fig. 40: Steering Wheel & Steering Shaft
Courtesy of GENERAL MOTORS CORP.

2. Verify the following before removing the SIR coil:
 - The wheels on the vehicle are straight ahead.

- That J 42640 is installed or the ignition switch is in the LOCK position.
3. Remove the steering wheel from the steering shaft. Refer to **Steering Wheel Replacement** in Steering Wheel and Column.

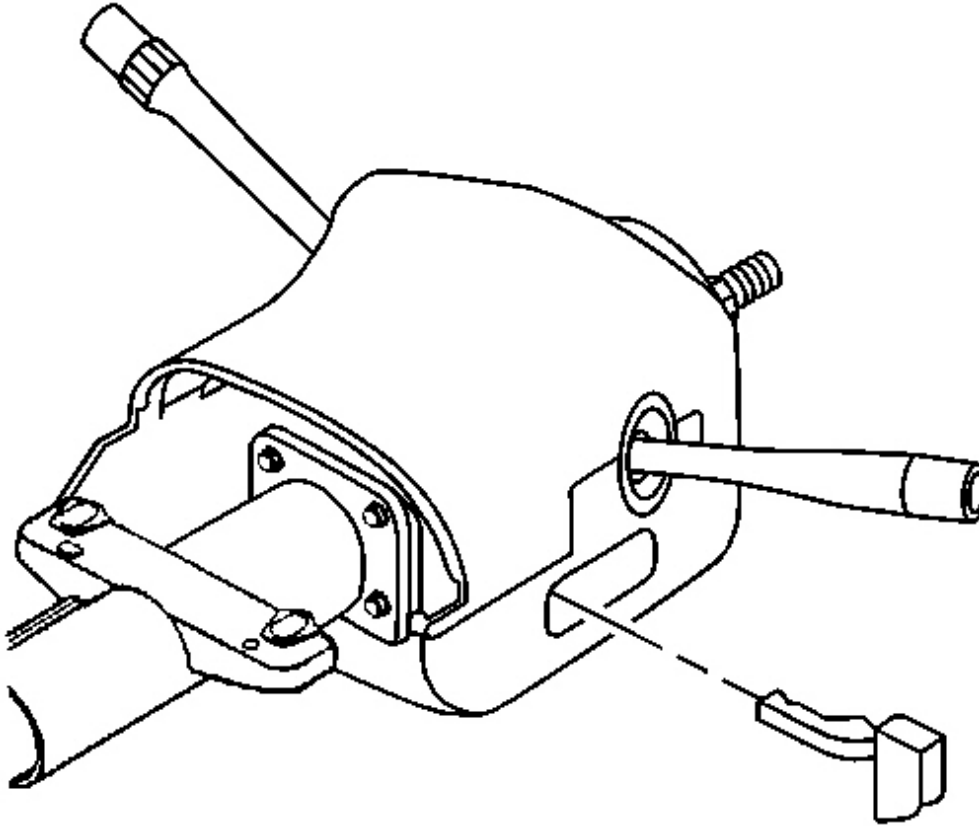

Fig. 41: Tilt Lever & Steering Column
Courtesy of GENERAL MOTORS CORP.

4. On vehicles with a tilt column, pull the tilt lever straight out from the steering column.

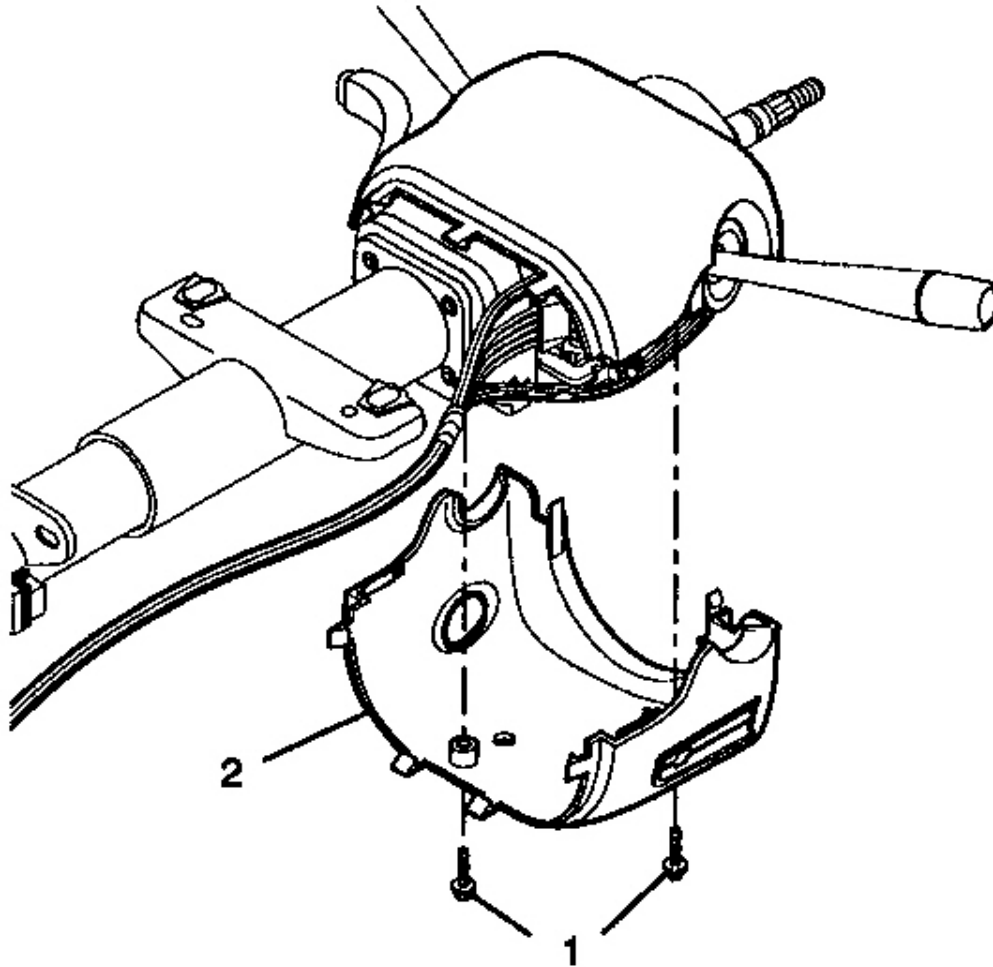

Fig. 42: Identifying Lower Trim Cover
Courtesy of GENERAL MOTORS CORP.

5. Remove 2 TORX(R) head screws (1) from the lower trim cover (2).
6. Remove the lower trim cover (2).

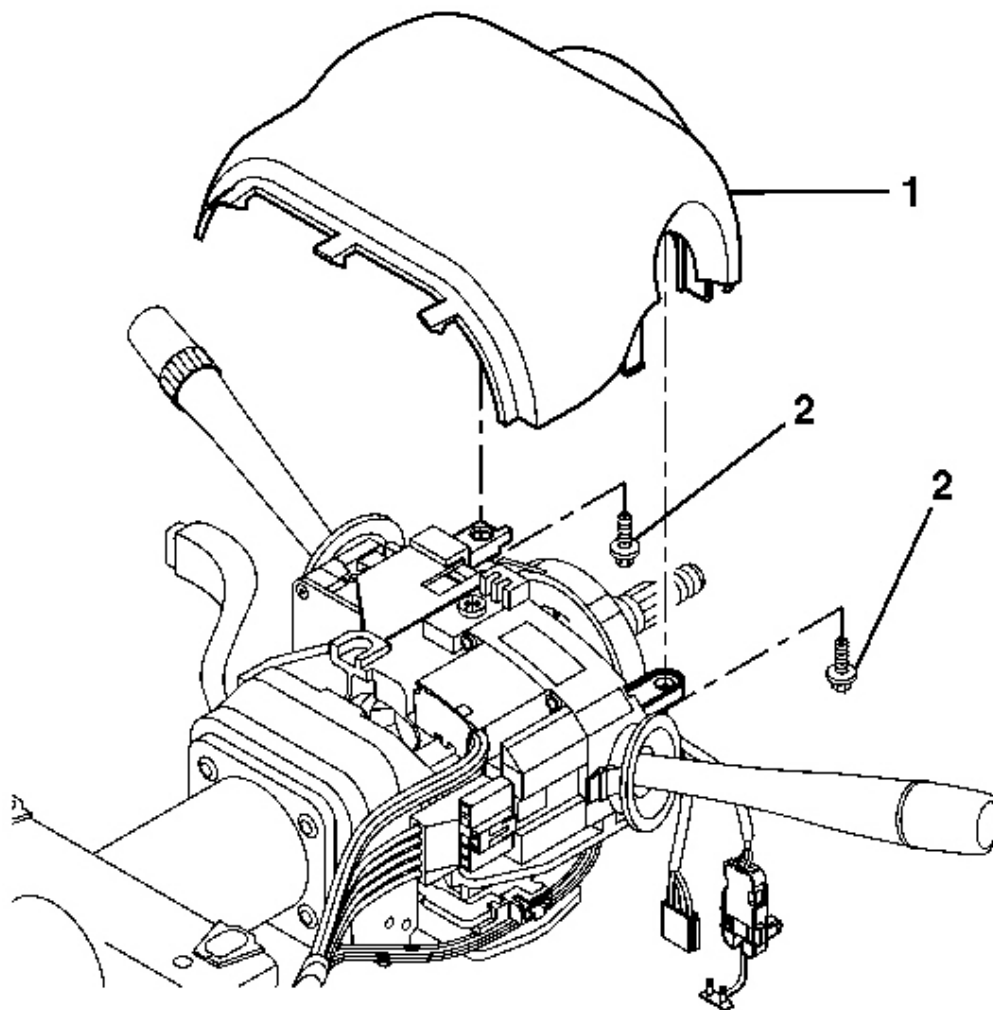

Fig. 43: Identifying Upper Trim Cover
Courtesy of GENERAL MOTORS CORP.

7. Remove 2 TORX(R) head screws (2) from the upper trim cover (1).
8. Remove the upper trim cover (1).

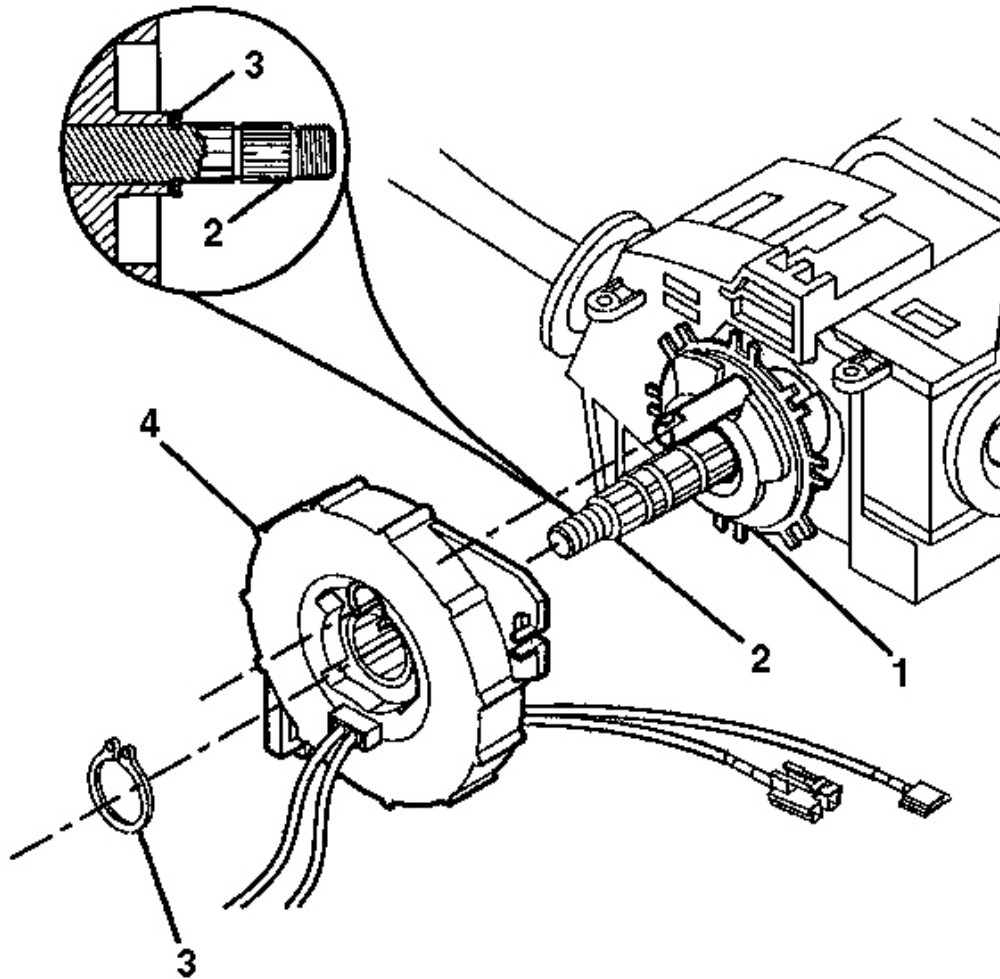

Fig. 44: Identifying SIR Coil
Courtesy of GENERAL MOTORS CORP.

9. Remove the wire harness straps from the steering wheel column wire harness.
10. Remove the retaining ring (3).
11. Remove the SIR coil (4) from the steering shaft.
12. If replacing, discard the SIR coil.

Installation Procedure

NOTE: The new SIR coil assembly will be centered. Improper alignment of the SIR

coil assembly may damage the unit, causing an inflatable restraint malfunction.

NOTE:

The wheels of the vehicle must be straight ahead and the steering column in the LOCK position before disconnecting the steering column or intermediate shaft from the steering gear. Failure to do so will cause the SIR coil assembly to become uncentered, which may cause damage to the coil assembly.

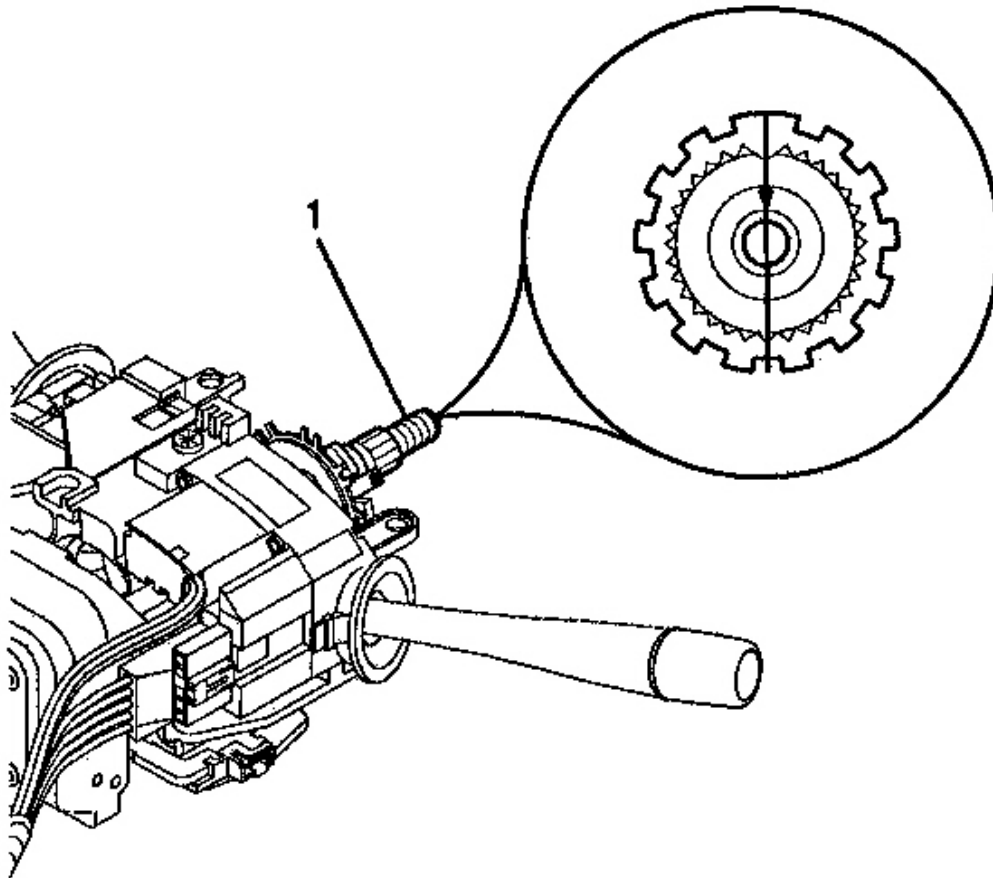

Fig. 45: Block Tooth Of Steering Shaft Assembly In 12 O'clock Position
Courtesy of GENERAL MOTORS CORP.

1. Verify the following:
 - The wheels on the vehicle are straight ahead.

- That J 42640 is installed or the ignition switch is in the LOCK position.

IMPORTANT: Do not remove the centering tab from the new SIR coil until the installation is complete. If the SIR coil does not come with a centering tab, you must center the SIR coil.

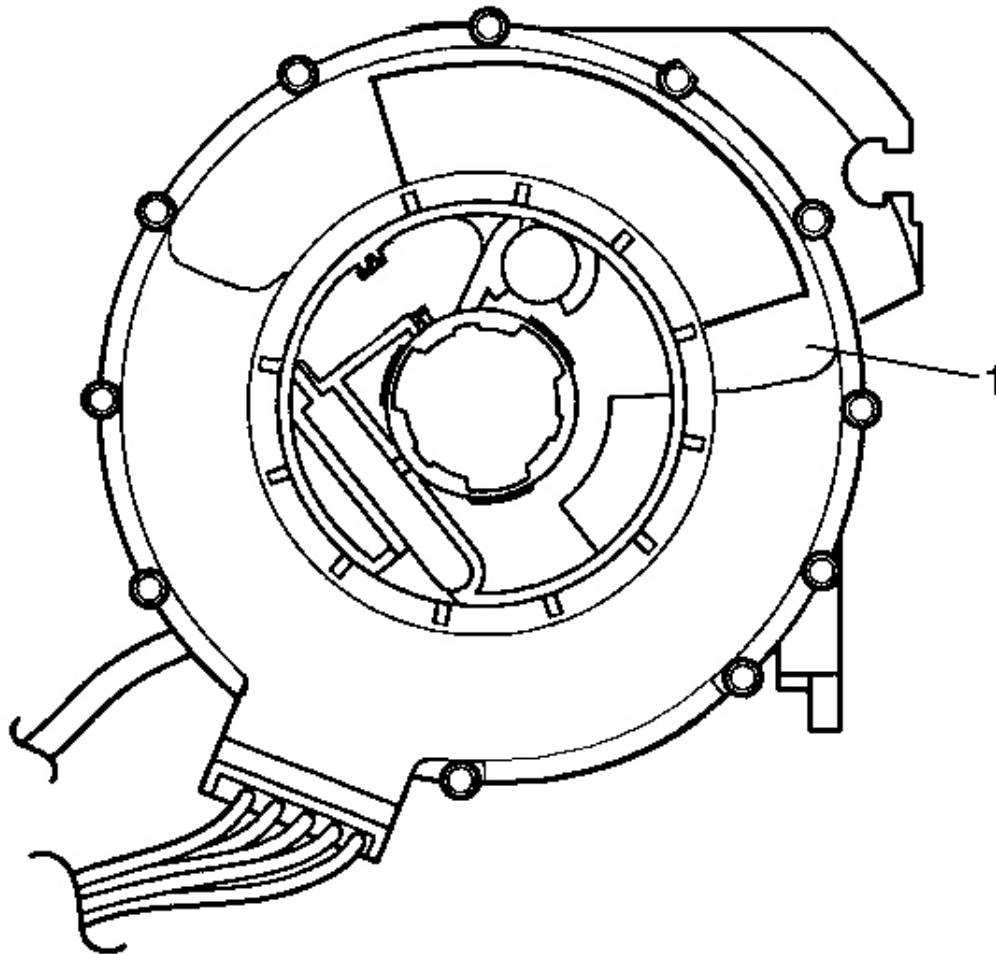

Fig. 46: SIR Coil
Courtesy of GENERAL MOTORS CORP.

2. If reusing the existing coil it MUST be centered, refer to **Inflatable Restraint Steering Wheel Module Coil Centering** in Steering Wheel and Column.

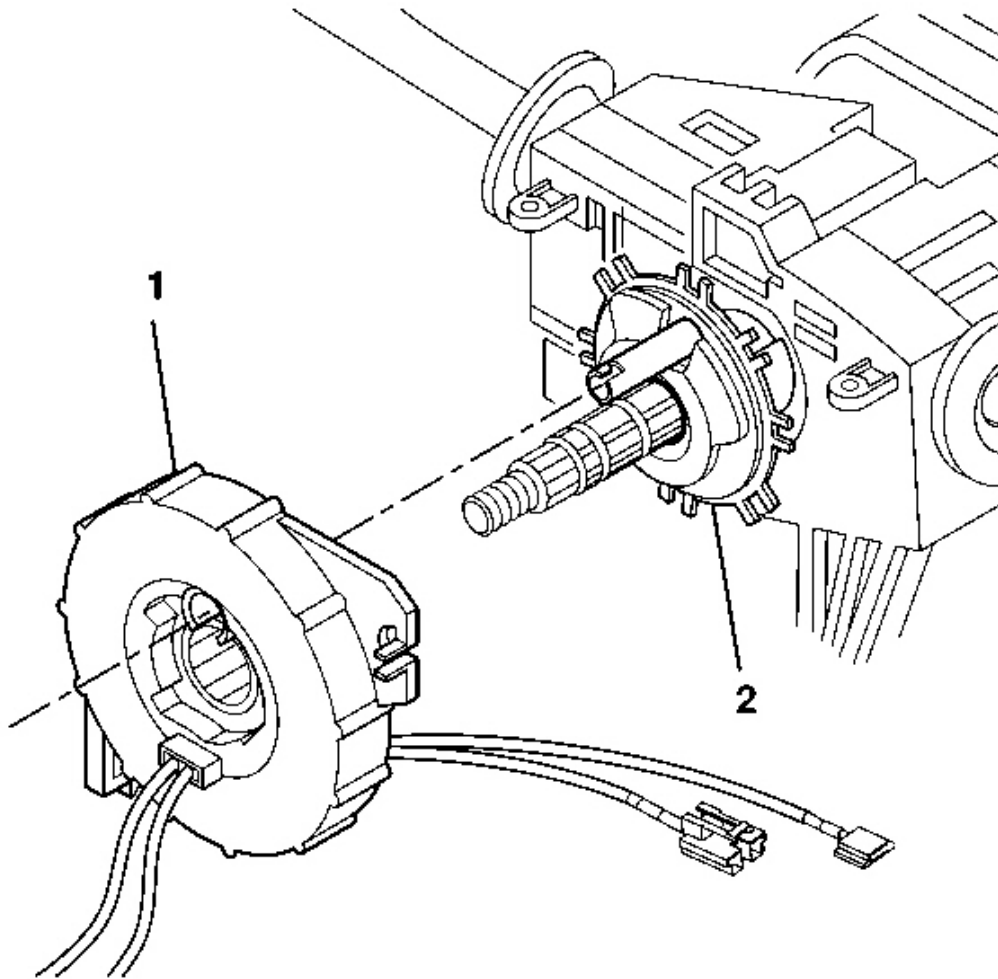

Fig. 47: Aligning SIR Coil Assembly With Horn Tower
Courtesy of GENERAL MOTORS CORP.

3. Align the SIR coil assembly (1) with the horn tower on the turn signal cancel cam assembly (2).
4. Slide the SIR coil (4) onto the steering shaft assembly (2).
5. Firmly seat the retaining ring (3) into the groove on the steering shaft assembly (2).

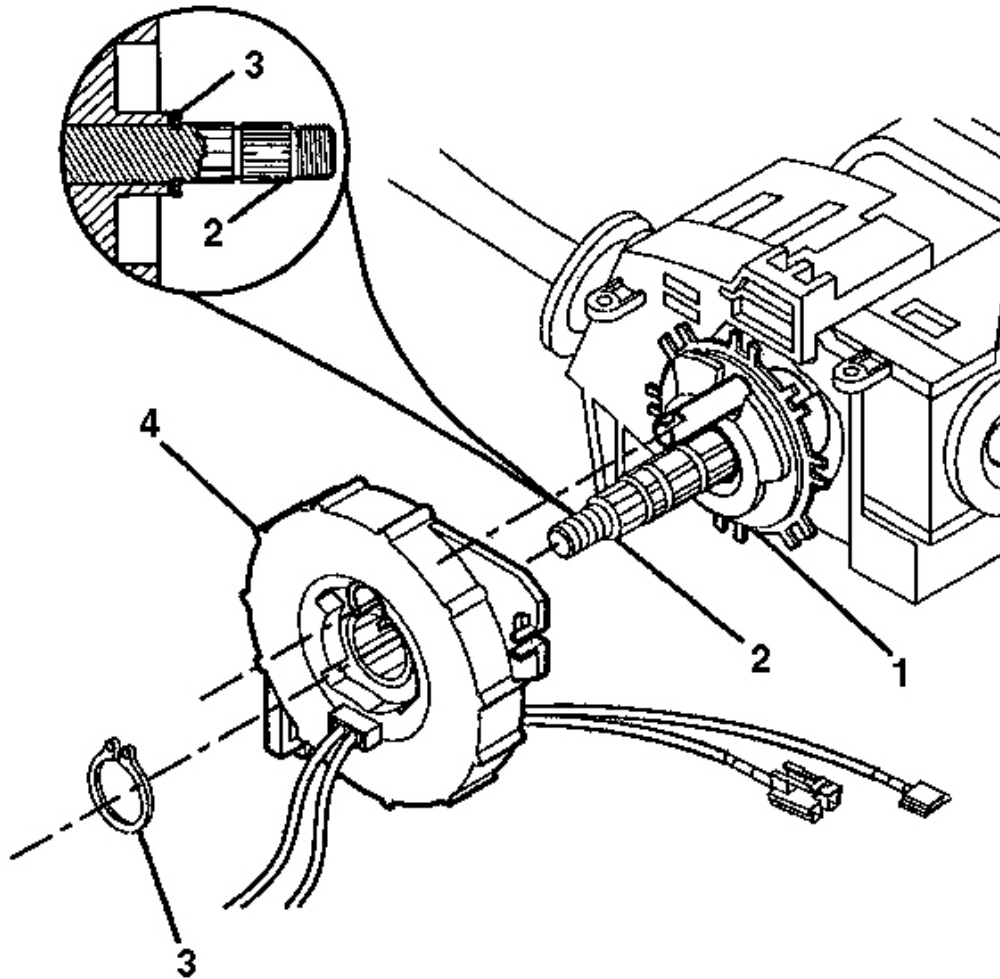

Fig. 48: Seating The Retaining Ring Into The Groove On The Steering Shaft Assembly
Courtesy of GENERAL MOTORS CORP.

6. Remove and discard the centering tab from the new SIR coil (4).

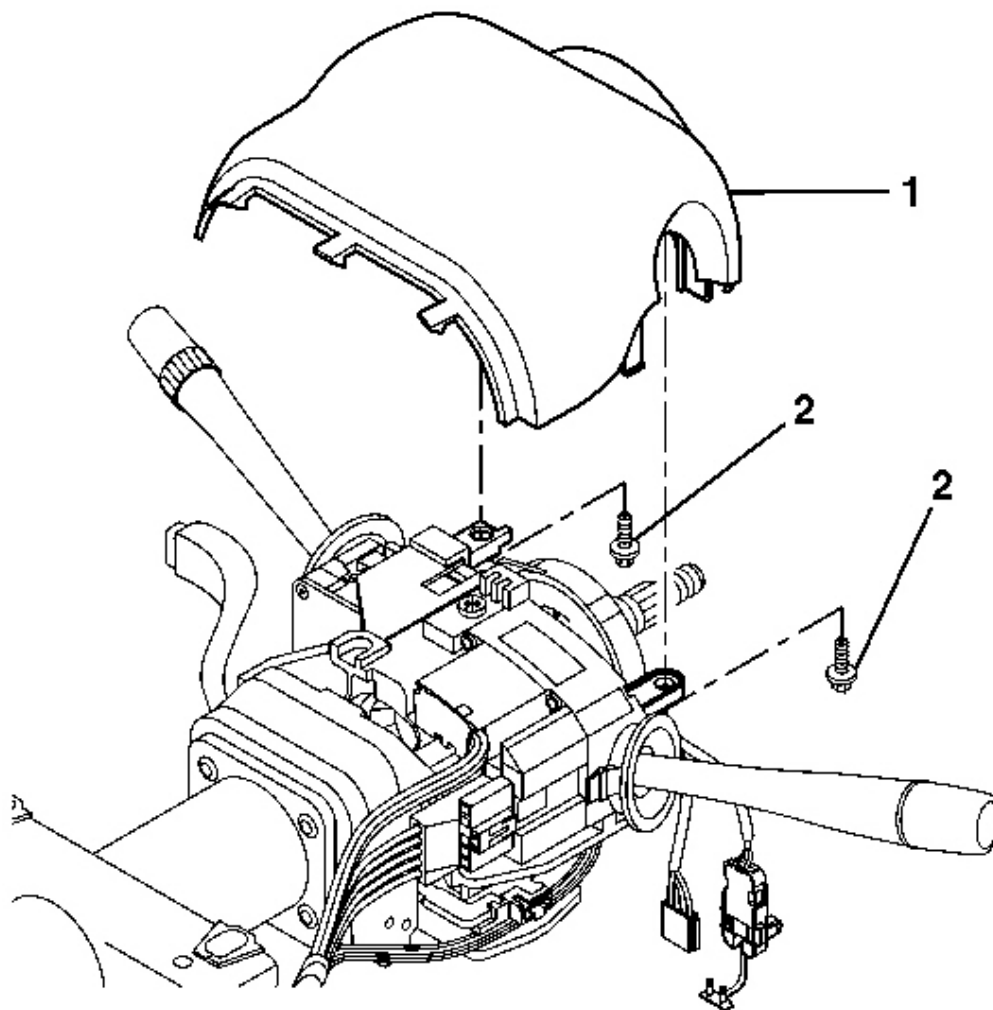

Fig. 49: Identifying Upper Trim Cover
Courtesy of GENERAL MOTORS CORP.

NOTE: Refer to **Fastener Notice** in **Cautions and Notices**.

7. Install the upper trim cover (1) and secure by using 2 TORX(R) head screws (2).

Tighten: Tighten the screws to 1.5 N.m (13 lb in).

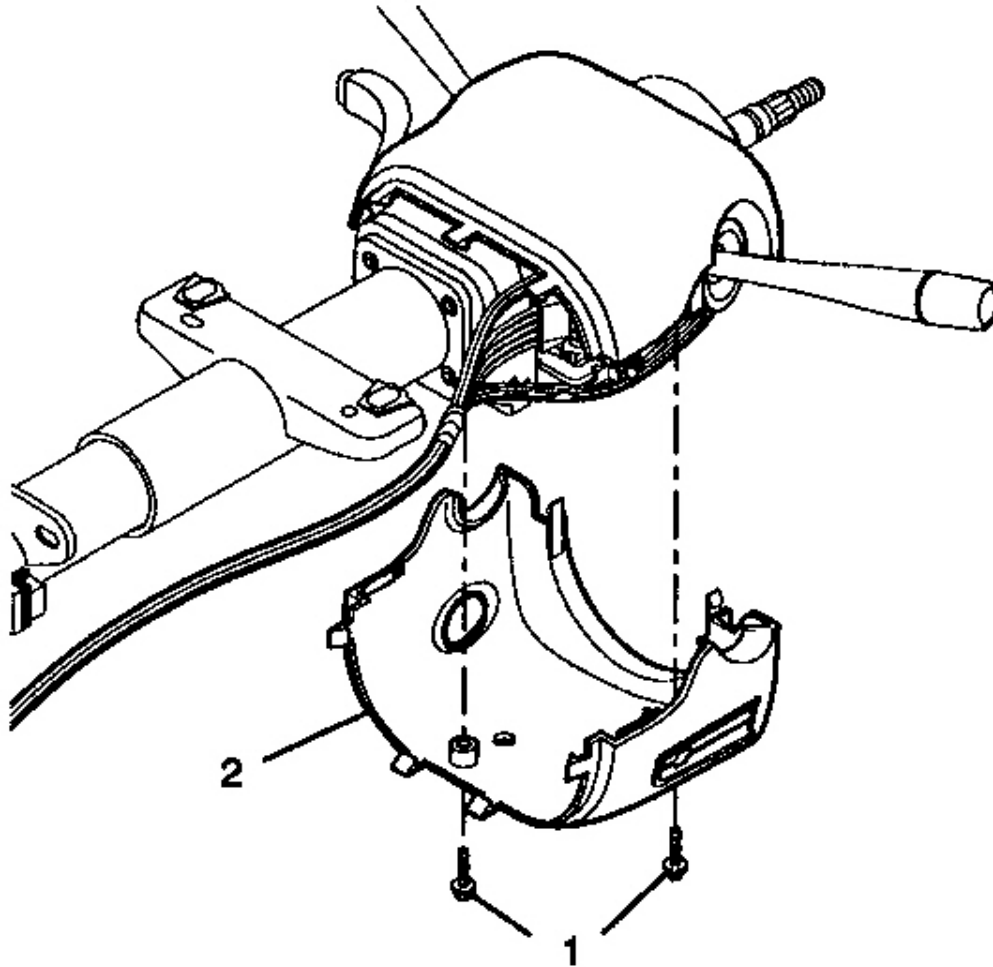

Fig. 50: Identifying Lower Trim Cover
Courtesy of GENERAL MOTORS CORP.

8. Install the lower trim cover (2) and secure by using 2 TORX(R) head screws (1).

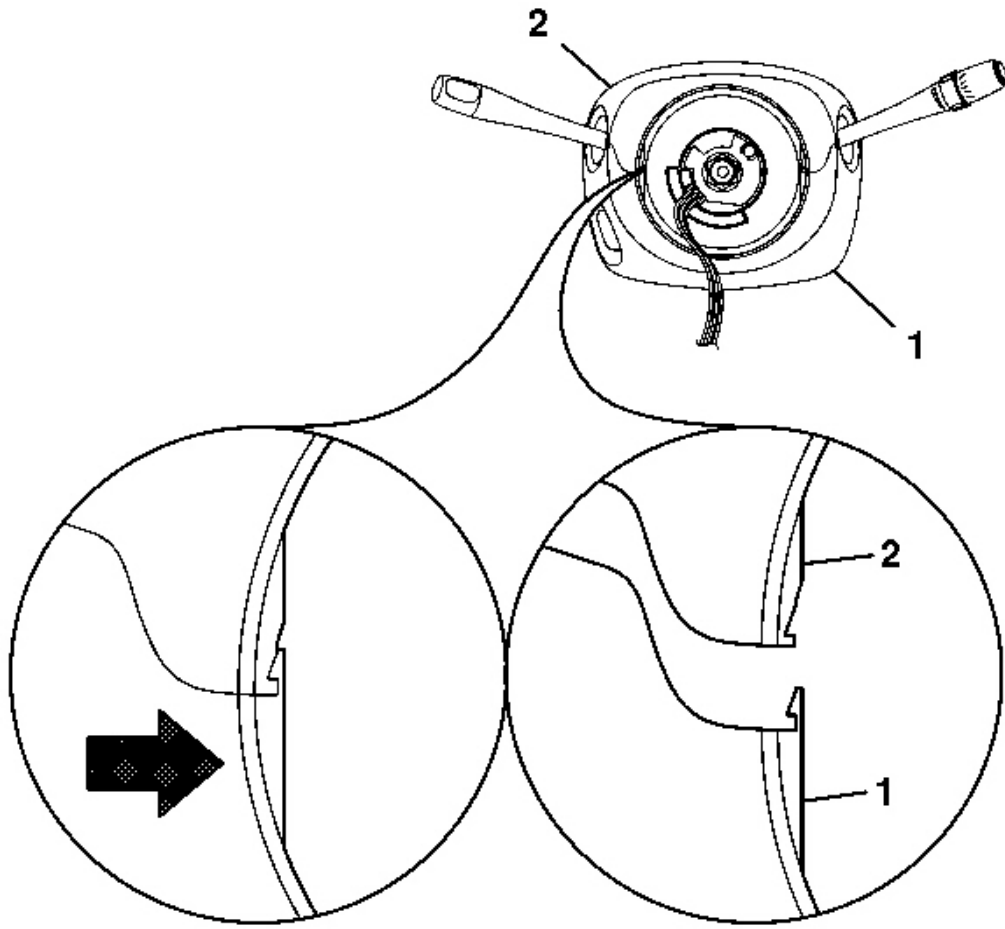

Fig. 51: Engaging Upper & Lower Trim Cover Tabs
Courtesy of GENERAL MOTORS CORP.

9. Verify that the tabs on the lower trim cover (1) engage with the tabs on the upper trim cover (2). Snap the tabs together.

Tighten: Tighten the screws to 1.5 N.m (13 lb in).

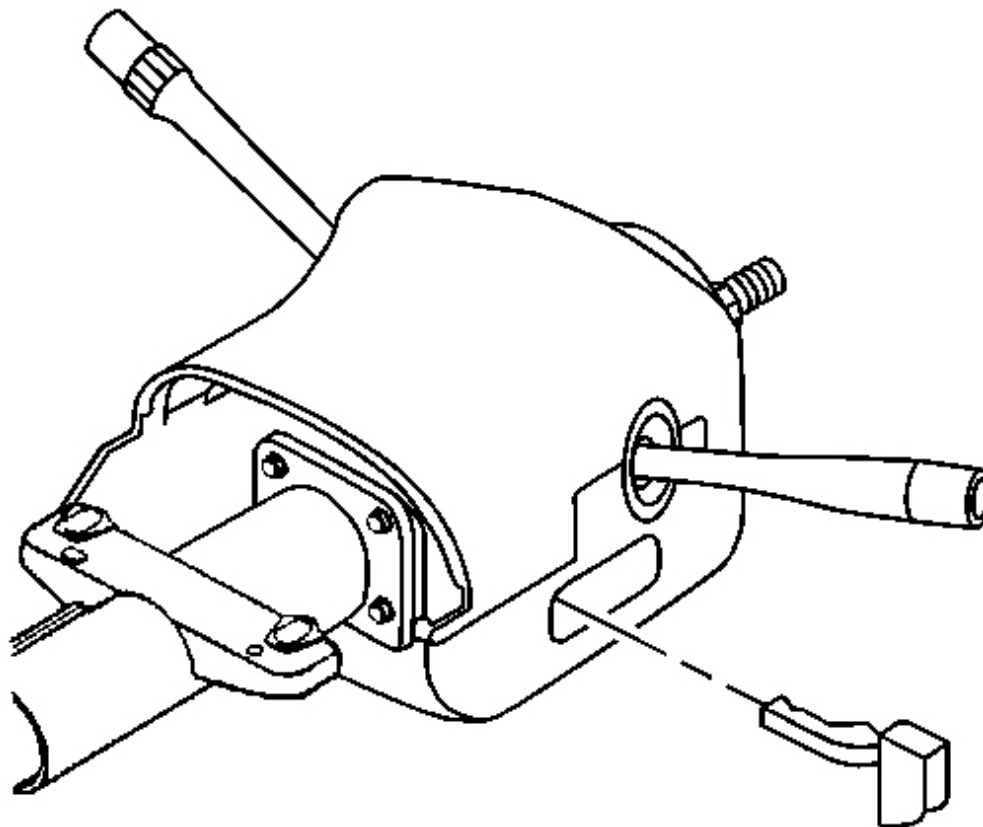

Fig. 52: Tilt Lever & Steering Column
Courtesy of GENERAL MOTORS CORP.

10. On vehicles with a tilt column, align the tilt lever into the steering column.
11. Slide the tilt lever handle into the steering column until the handle locks into position.

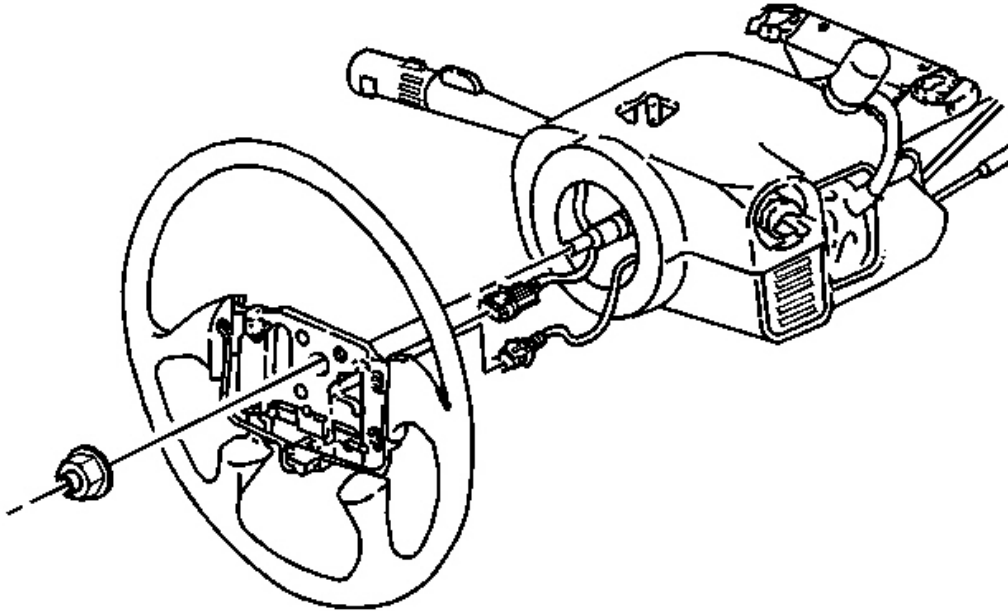

Fig. 53: Steering Wheel & Steering Shaft
Courtesy of GENERAL MOTORS CORP.

12. Install the steering wheel onto the steering shaft. Refer to **Steering Wheel Replacement** in Steering Wheel and Column.
13. Enable the SIR system. Refer to **SIR Disabling and Enabling Zone 3** .

INFLATABLE RESTRAINT INSTRUMENT PANEL MODULE REPLACEMENT

CAUTION: Refer to **SIR Caution** in Cautions and Notices.

CAUTION: Refer to **SIR Inflator Module Handling and Storage Caution** in Cautions and Notices.

Removal Procedure

1. Remove trim panel replacement-I/P accessory right- from the I/P substraight (1). Refer to **Trim Plate Replacement - Instrument Panel (I/P) Accessory Right** in Instrument Panel, Gauges and Console.
2. Disable the SIR system (2). Refer to **SIR Disabling and Enabling Zones** .

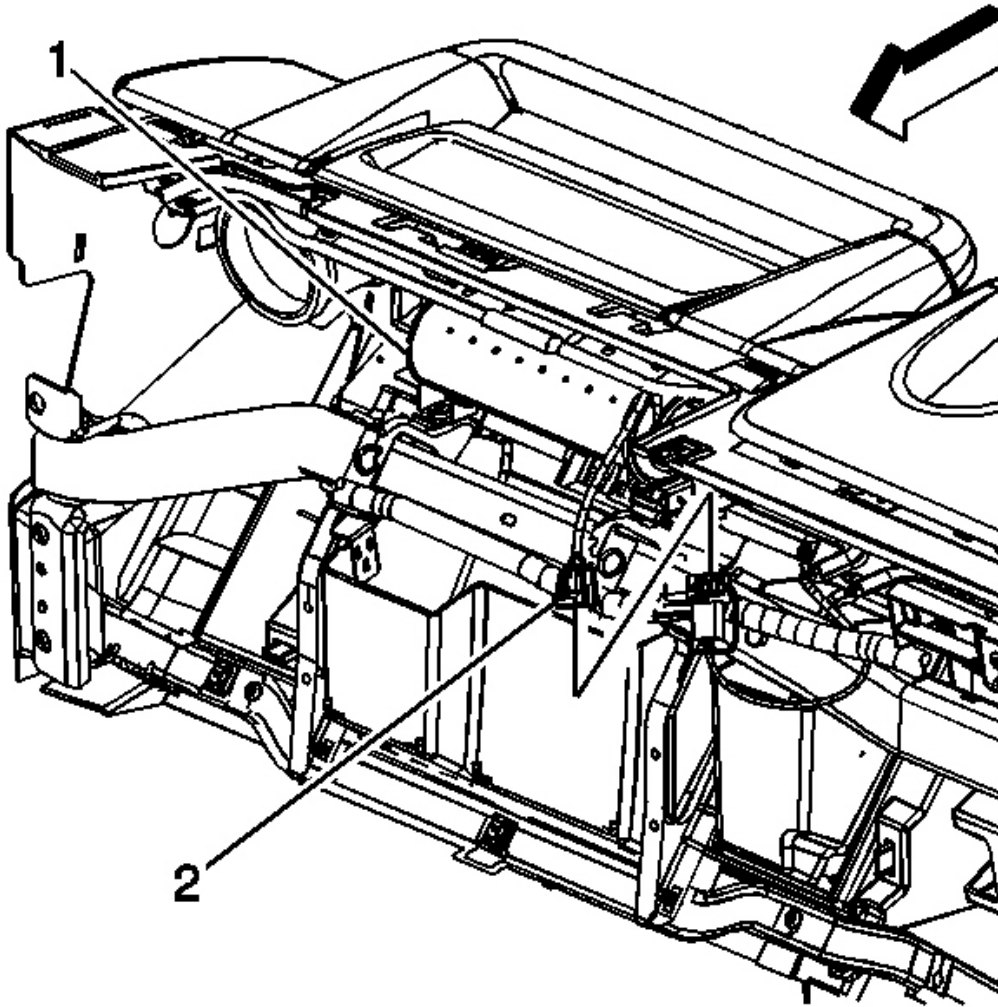

Fig. 54: Inflatable Restraint I/P Module
Courtesy of GENERAL MOTORS CORP.

3. Remove the connector from the I/P.

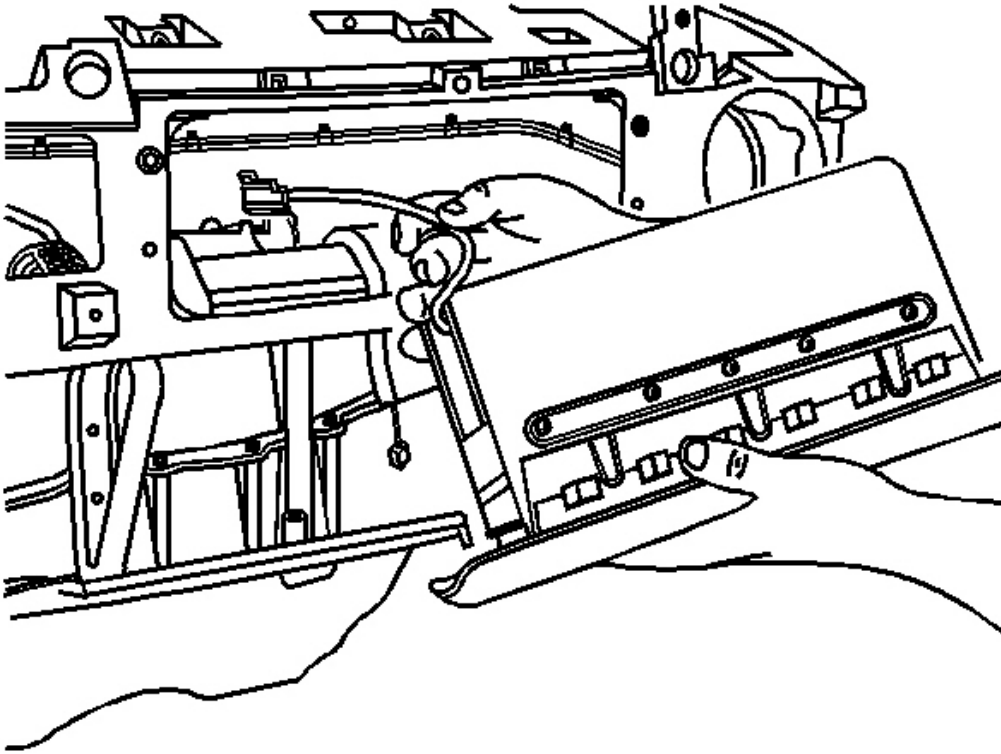

Fig. 55: Removing Inflatable Restraint I/P Module Retaining Bolts
Courtesy of GENERAL MOTORS CORP.

4. Remove the inflatable restraint I/P module retaining bolts.
5. Ensure that you keep a firm hold on the I/P module.

Installation Procedure

1. Install the inflatable restraint I/P module (1) to the mounting bracket through the front of the instrument panel.

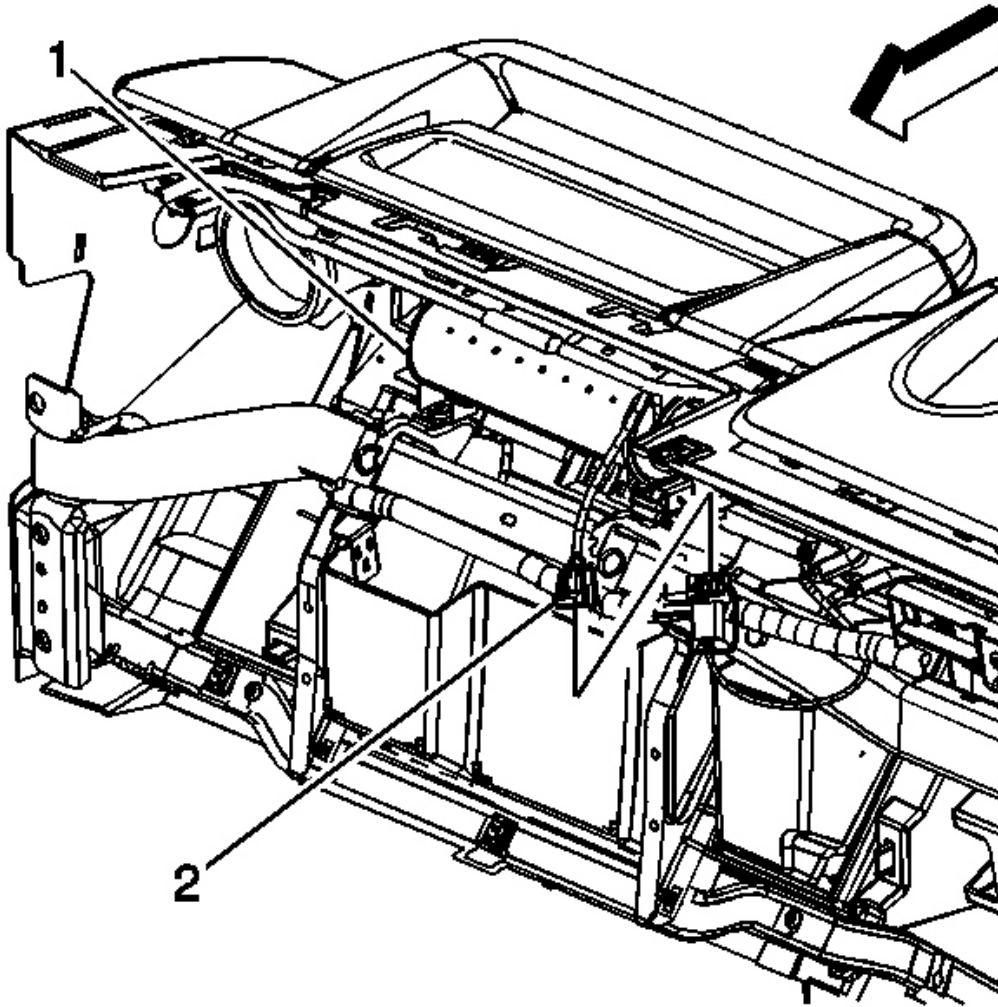

Fig. 56: Inflatable Restraint I/P Module
Courtesy of GENERAL MOTORS CORP.

NOTE: Refer to Fastener Notice in Cautions and Notices.

2. Install the fasteners (2) to the inflatable restraint I/P module.

Tighten: Tighten the fasteners to 10 N.m (89 lb in).

3. Enable the SIR system. Refer to SIR Disabling and Enabling Zones.
4. Install the yellow connector to the I/P.

5. Install the trim panel to the substraight. Refer to **Trim Plate Replacement - Instrument Panel (I/P) Accessory Right** in Instrument Panel, Gauges and Console.

INFLATABLE RESTRAINT INSTRUMENT PANEL (I/P) MODULE DISABLE SWITCH REPLACEMENT

CAUTION: Refer to **SIR Caution** in Cautions and Notices.

Removal Procedure

1. Remove the instrument panel trim bezel. Refer to **Trim Panel Replacement - Instrument Panel (I/P) Cluster** in Instrument Panel, Gauges and Console.

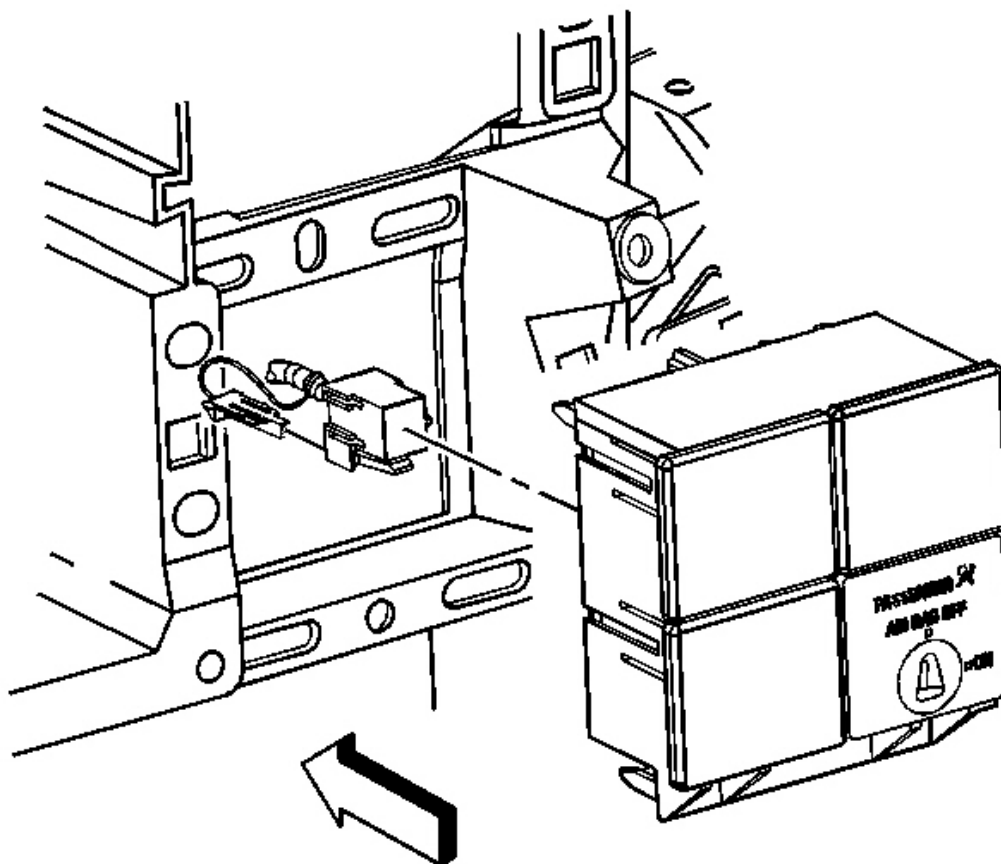

Fig. 57: Inflation Restraint Instrument Panel (I/P) Module Disable Switch

Courtesy of GENERAL MOTORS CORP.

2. Remove the I/P module switch from the lower right opening of the switch plate panel.
3. Disconnect the I/P module switch electrical connector.

Installation Procedure

1. Connect the I/P module switch electrical connector.

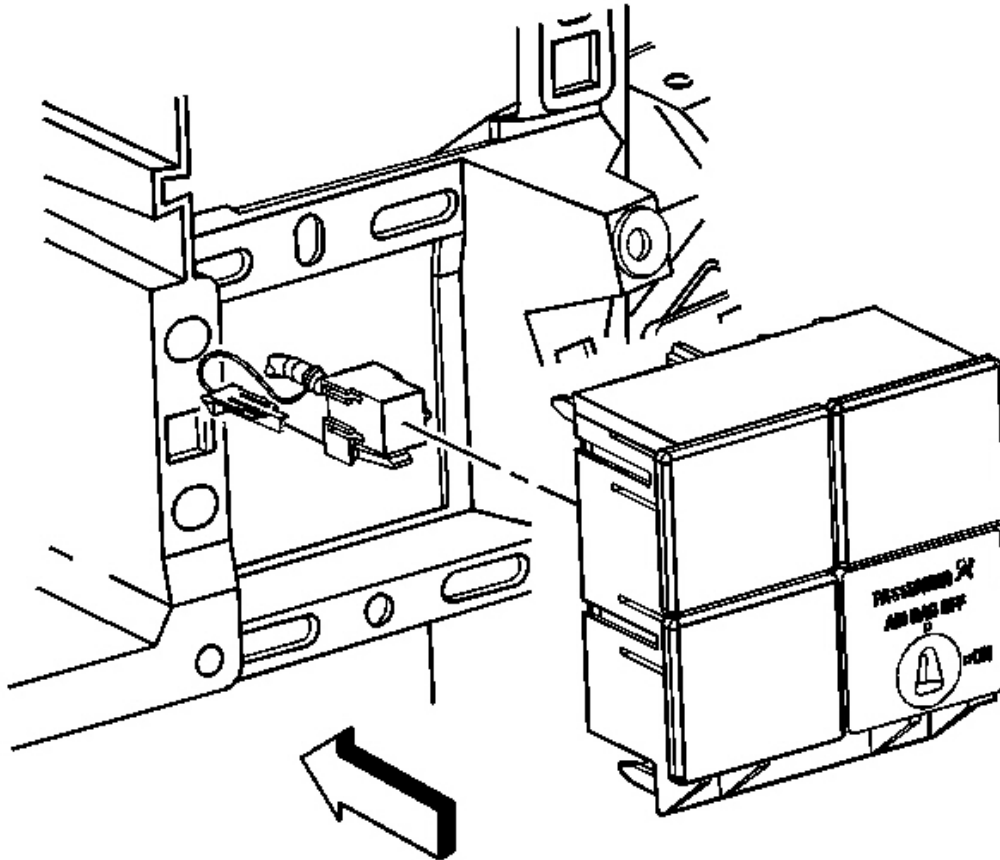

Fig. 58: Inflation Restraint Instrument Panel (I/P) Module Disable Switch
Courtesy of GENERAL MOTORS CORP.

2. Install the I/P module switch into the lower right opening of the switch plate panel.
3. Install the instrument panel trim bezel. Refer to **Trim Panel Replacement - Instrument Panel (I/P) Cluster** in Instrument Panel, Gauges and Console.

REPAIRS AND INSPECTIONS REQUIRED AFTER A COLLISION

CAUTION: Proper operation of the SIR sensing system requires that any repairs to the vehicle structure return the vehicle structure to the original production configuration. Not properly repairing the vehicle structure could cause non-deployment in a collision or deployment for conditions less severe than intended.

Accident With or Without Inflator Module Deployment - Component Inspections

After any collision, inspect the following components as indicated. If you detect any damage, replace the component. If you detect any damage to the mounting points or mounting hardware, repair or replace the mounting points and mounting hardware as needed.

- The steering column - Perform the steering column accident damage checking procedures. Refer to **Steering Column Accident Damage Inspection** in Steering Wheel and Column.
- The I/P knee bolsters and mounting points - Inspect the knee bolsters for bending, twisting, buckling, or any other type of damage.
- The I/P brackets, braces, etc.- Inspect for bending, twisting, buckling, or any other type of damage.
- The seat belts - Perform the seat belt operational and functional checks. Refer to **Operational and Functional Checks** in Seat Belts.
- The I/P cross car beam - Inspect for bending, twisting, buckling, or any other type of damage.
- The I/P mounting points and brackets - Inspect for bending, twisting, buckling, or any other type of damage.
- The seats and seat mounting points - Inspect for bending, twisting, buckling, or any other type of damage.

Accident With Frontal Air Bag Deployment - Component Replacement and Inspections

After a collision involving air bag deployment, replace the following components. If you detect any damage to the mounting points or mounting hardware, repair or replace the mounting points and mounting hardware as needed.

- Inflatable restraint I/P module
- Inflatable restraint steering wheel module
- Inflatable restraint steering wheel module coil
- Inflatable restraint sensing and diagnostic module (SDM)
- Inflatable restraint electronic frontal sensor (EFS)

Perform additional inspections on the following components.

- Steering wheel module coil and the coil wiring pigtail - Inspect for melting, scorching, or other damage due to excessive heat.
- Mounting points or mounting hardware for the I/P module, steering wheel module, SDM, and EFS sensor - Inspect for any damage and repair or replace each component as needed.

Sensor Replacement Guidelines

The SIR/side air bag sensor replacement policy requires replacing sensors in the area of accident damage. The area of accident damage is defined as the portion of the vehicle which is crushed, bent, or damaged due to a collision. An example of this would be a moderate collision where the front of the vehicle impacts a tree, if the vehicle has an SIR sensor mounted forward of the radiator, replace the SIR sensor.

- Replace the sensor whether or not the air bags have deployed.
- Replace the sensor even if the sensor appears to be undamaged.

Sensor damage which is not visible, such as slight bending of the mounting bracket or cuts in the wire insulation, can cause improper operation of the SIR/side air bag sensing system. Do not try to determine whether the sensor is undamaged. Replace the sensor. Also, if you follow a Diagnostic Trouble Code (DTC) table and a malfunctioning sensor is indicated, replace the sensor.

INFLATOR MODULE HANDLING AND SCRAPPING

CAUTION: Refer to SIR Inflator Module Handling and Storage Caution in Cautions and Notices.

Live (Undeployed) Inflator Modules

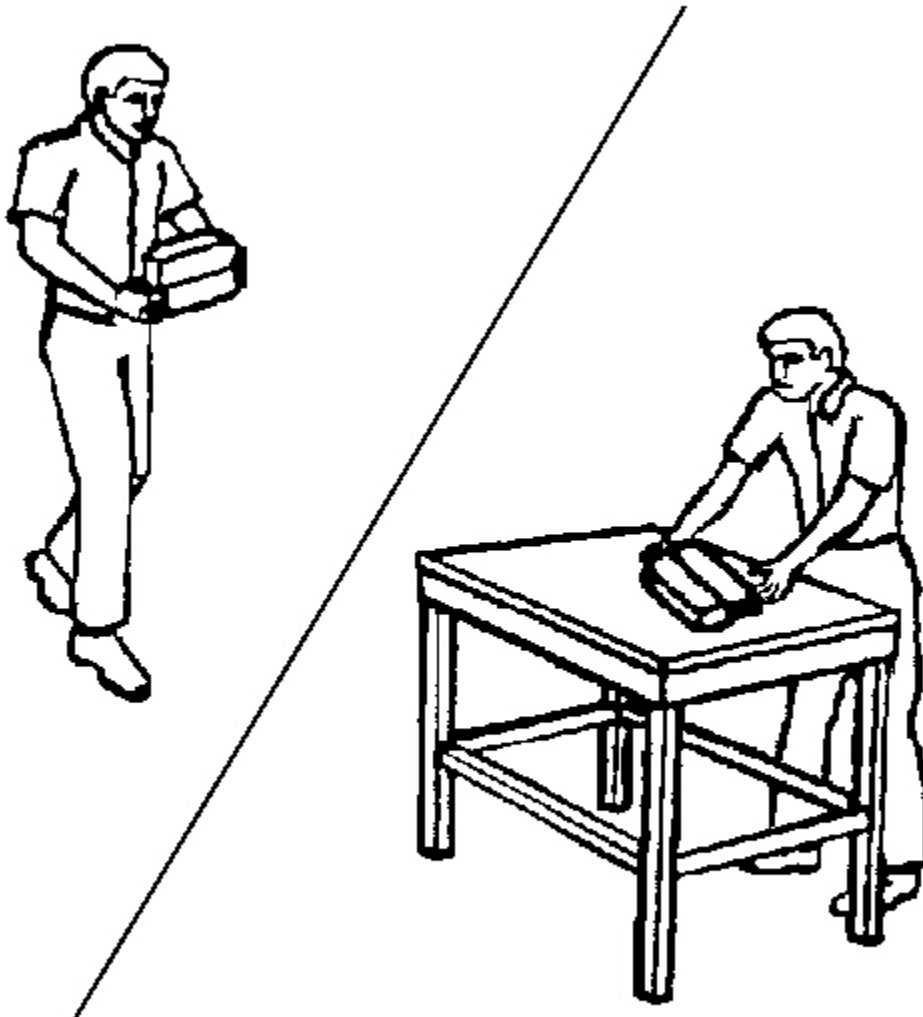

Fig. 59: Handling Undeployed Inflator Module
Courtesy of GENERAL MOTORS CORP.

Use special care when handling or storing live, undeployed, inflator modules. Inflator module deployment produces a rapid generation of gas. This may cause the inflator module, or an object in front of the inflator module, to project through the air in the event of an unlikely deployment.

Scrapping Procedures

During the course of a vehicle's useful life, certain situations may arise which will require the disposal of a live,

undeployed, inflator module. Do not dispose of a live, undeployed, inflator module through normal disposal channels until the inflator module has been deployed. The following information covers the proper procedures for disposing of a live, undeployed, inflator module.

Do not deploy an inflator module in the following situations:

- After replacement of an inflator module under warranty. The inflator module may need to be returned undeployed to the manufacturer.
- If the vehicle is the subject of a product liability report (GM-1241) related to the SIR system. When a vehicle is the subject of a product liability report, do not alter the SIR system in any manner.
- If the vehicle is involved in a campaign affecting the inflator modules. Follow the instructions in the Campaign Service Bulletin for proper SIR handling procedures.

Deployment Procedures

Inflator modules can be deployed inside or outside of the vehicle. The method used depends upon the final disposition of the vehicle. Review the following procedures in order to determine which will work best in a given situation.

Deployment Outside Vehicle-IP Module and Steering Wheel Module

Deploy inflator modules outside of the vehicle when the vehicle will be returned to service. Situations that require deployment outside of the vehicle include the following:

- Using the SIR diagnostics, you determine that the inflator module is malfunctioning.
- The inflator module is cosmetically damaged (scratched or ripped).
- The inflator module pigtail, if equipped, is damaged.
- The inflator module connector is damaged.
- The inflator module connector terminals are damaged.

Deployment and disposal of a malfunctioning inflator module is subject to any required retention period.

CAUTION: Refer to SIR Inflator Module Disposal Caution in Cautions and Notices.

Tools Required

- **J 38826** SIR Deployment Harness. See **Special Tools and Equipment** .
- **J 39401-B** SIR Deployment Fixture. See **Special Tools and Equipment** .
- An appropriate pigtail adaptor

1. Turn OFF the ignition.
2. Remove the ignition key.

3. Put on safety glasses.
4. Remove the inflator module. Refer to the following:
 - When removing the steering wheel module, refer to **Inflatable Restraint Steering Wheel Module Replacement** .
 - When removing the I/P module, refer to **Inflatable Restraint Instrument Panel Module Replacement** .

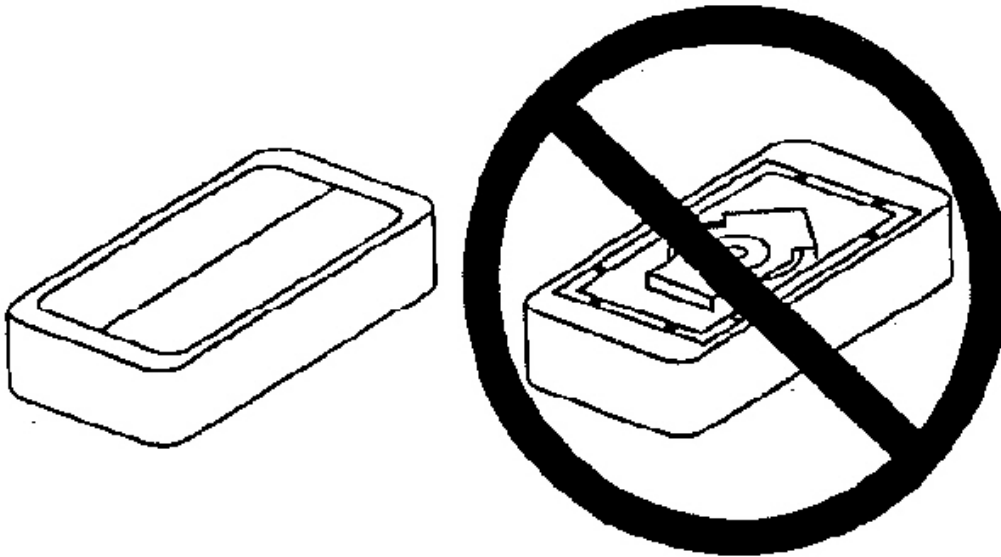

Fig. 60: Proper Storage Of Inflator Module
Courtesy of GENERAL MOTORS CORP.

5. Place the inflator module with the vinyl trim cover facing up and away from the surface on a work bench, floor or deployment fixture.

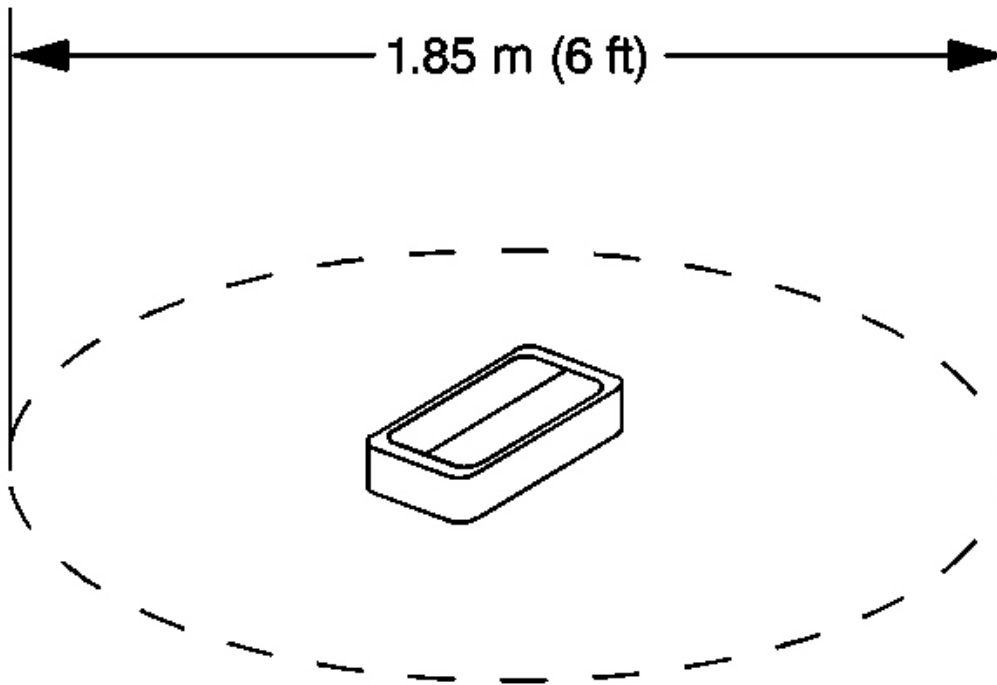

Fig. 61: Clearing Space For Deployment Of Inflator Module
Courtesy of GENERAL MOTORS CORP.

6. Clear an area on the floor approximately 1.85 m (6 ft) in diameter for deployment of the inflator module. If possible, use a paved, outdoor location free of activity. Otherwise, use an area free of activity on the shop floor. Ensure you have sufficient ventilation.
7. Ensure no loose or flammable objects are in the area.
8. When deploying a steering wheel module, place the steering wheel module in the center of the cleared area.

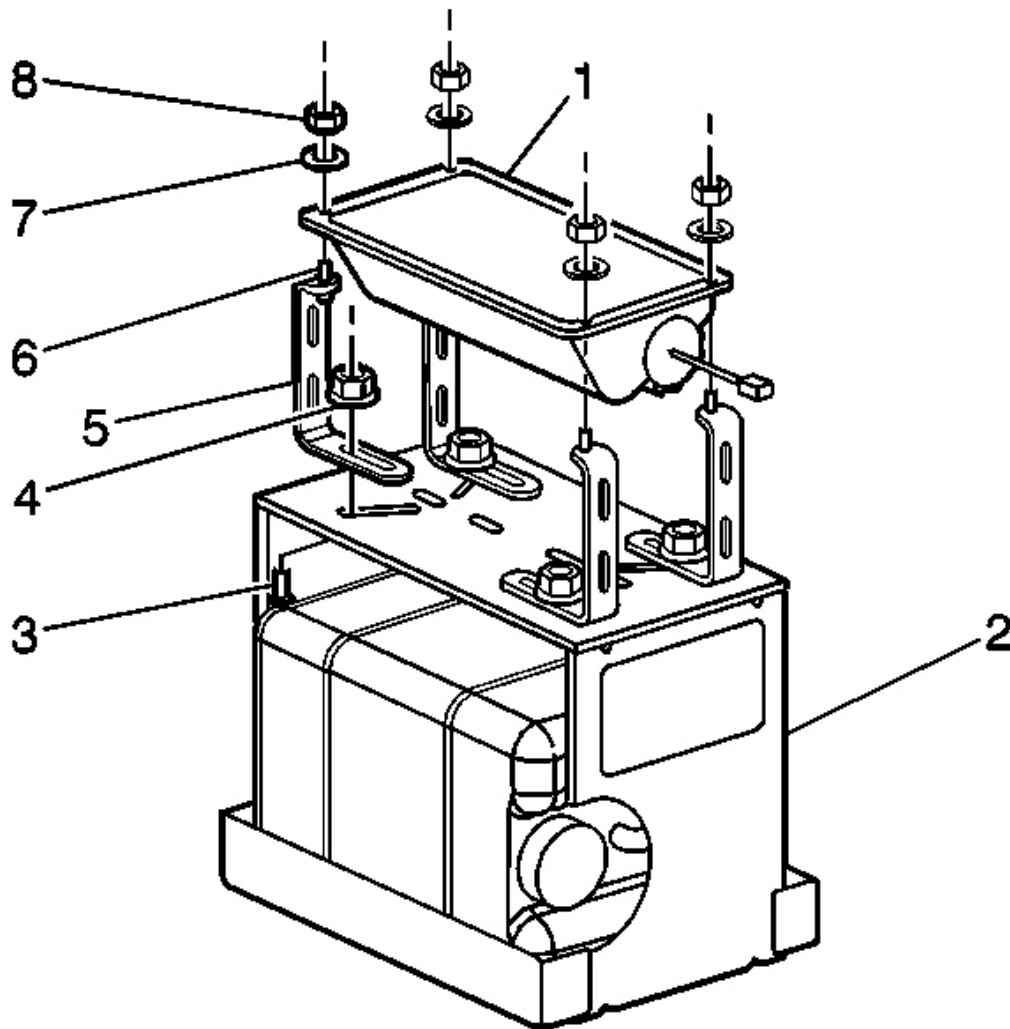

Fig. 62: I/P Module Components
Courtesy of GENERAL MOTORS CORP.

9. When deploying an I/P module, refer to the following instructions:
- Place the **J 39401-B** (2) in the center of the cleared area. See **Special Tools and Equipment** .
 - Fill the deployment fixture (2) with water or sand.
 - Mount the I/P module (1) in the deployment fixture (2) with the vinyl/plastic trim facing up.
 - To mount, use 4 M 6 bolts (6), nuts (8), and washers (7) to properly secure the I/P module (1) to the deployment fixture (2).
 - Tighten all fasteners prior to deployment.

10. Inspect the **J 38826** and the appropriate pigtail adapter for damage. Replace as needed. See **Special Tools and Equipment**.
11. Short the 2 SIR deployment harness (1) leads together using one banana plug seated into the other.

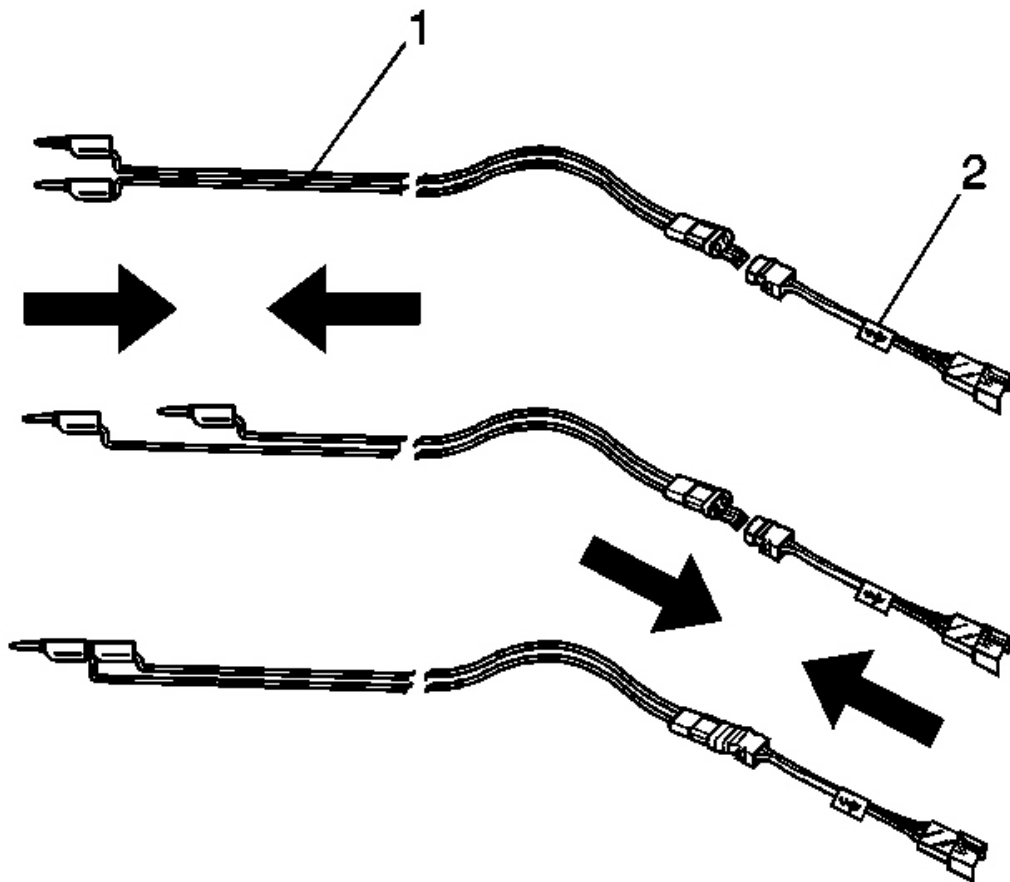

Fig. 63: SIR Deployment Harness & Adapter
Courtesy of GENERAL MOTORS CORP.

12. Connect the appropriate pigtail adapter (2) to the SIR deployment harness (1).

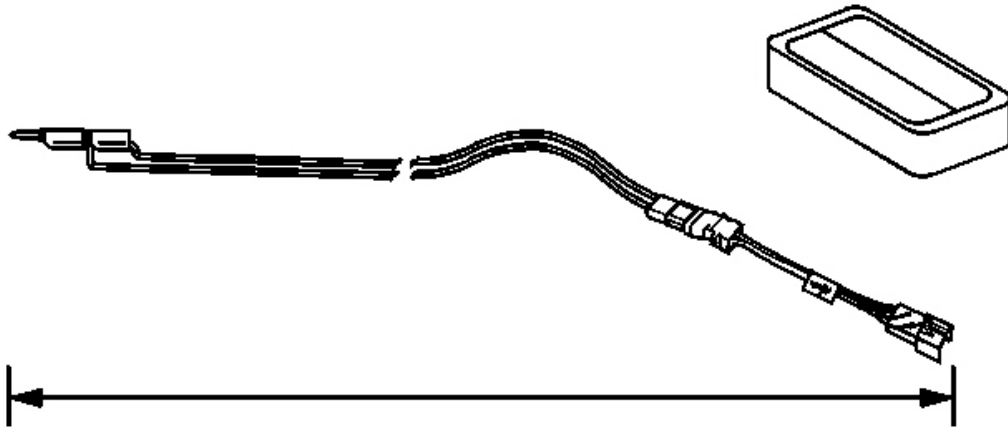

Fig. 64: Extending SIR Deployment Harness & Adapter
Courtesy of GENERAL MOTORS CORP.

13. Extend the SIR deployment harness and adapter to full length from the deployment fixture.

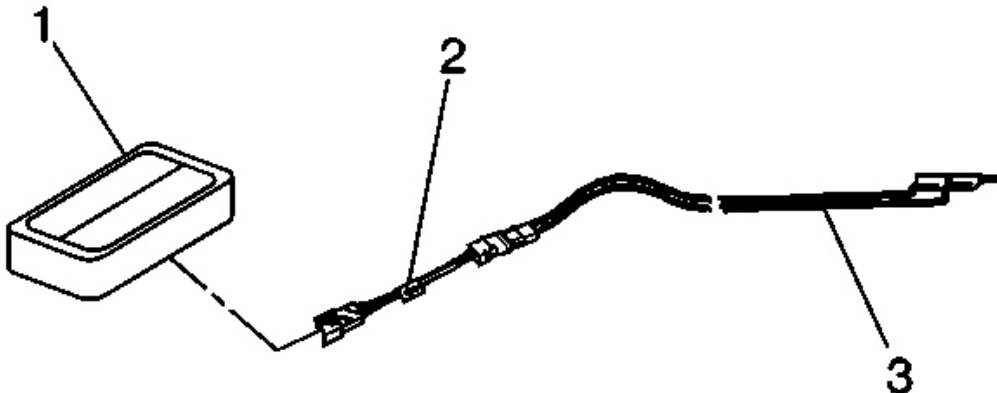

Fig. 65: Connecting Inflator Module To SIR Deployment Harness Adapter
Courtesy of GENERAL MOTORS CORP.

14. Connect the inflator module (1) to the adapter (2) on the SIR deployment harness (3).
15. Place a 12 V minimum/2 A minimum power source, i.e. vehicle battery, near the shorted end of the SIR

deployment harness.

IMPORTANT:

- The rapid expansion of gas involved with deploying an inflator module is very loud. Notify all people in the immediate area that an inflator module will be deployed.
- When the inflator module deploys, the deployment fixture may jump vertically. This is a normal reaction of the inflator module due to the force of the rapid expansion of gas inside the inflator module.

16. Clear the area of people.

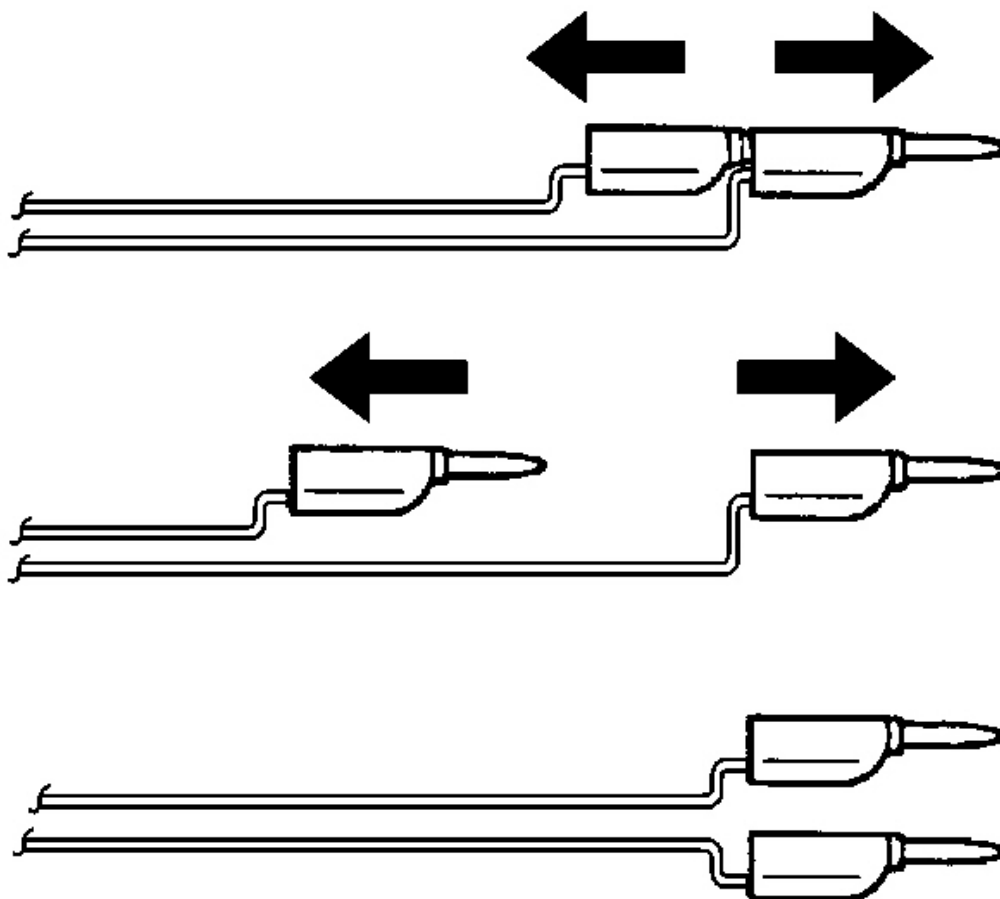

Fig. 66: Separating Banana Plugs
Courtesy of GENERAL MOTORS CORP.

17. Separate the 2 banana plugs on the SIR deployment harness.

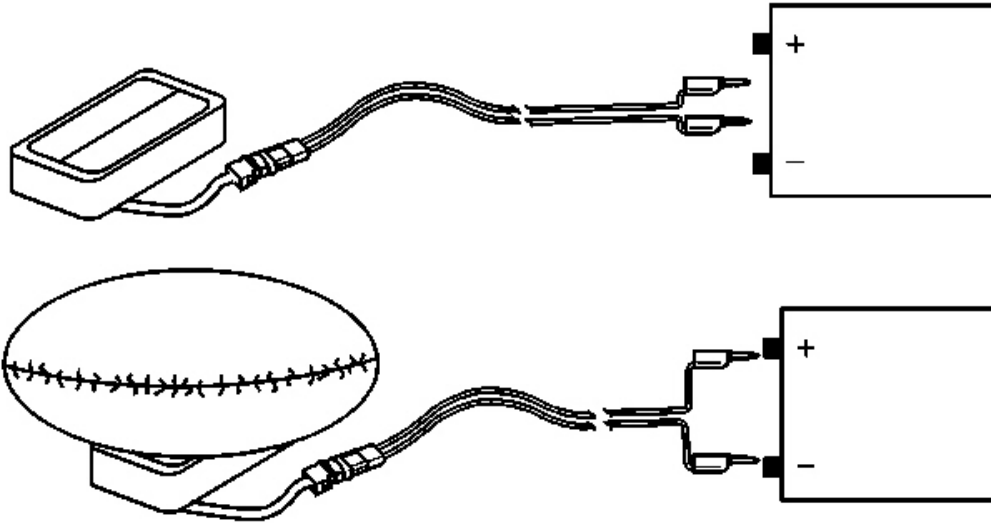

Fig. 67: Connecting SIR Deployment Harness Wires To Power Source
Courtesy of GENERAL MOTORS CORP.

18. Connect the SIR deployment harness wires to the power source. Inflator module deployment will occur when contact is made.
19. Disconnect the SIR deployment harness from the power source.

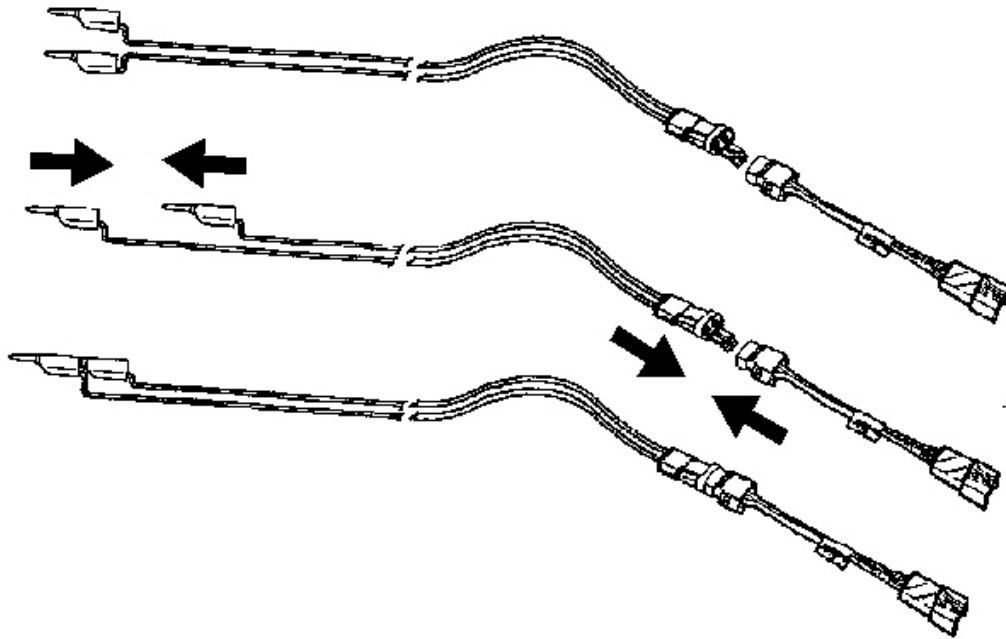

Fig. 68: Shorting Deployment Harness Leads
Courtesy of GENERAL MOTORS CORP.

CAUTION: Refer to SIR Deployed Inflator Modules Are Hot Caution in Cautions and Notices.

20. Seat 1 banana plug into the other in order to short the deployment harness leads.
21. If the inflator module did not deploy, disconnect the adapter and discontinue the procedure. Contact the Technical Assistance Group for further assistance. Otherwise, proceed to the following steps.

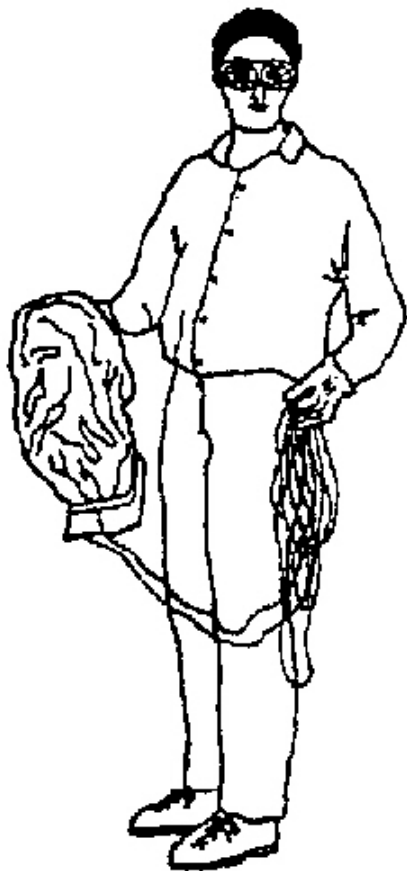

Fig. 69: Disposing Of Deployed Inflator Module
Courtesy of GENERAL MOTORS CORP.

22. Put on a pair of shop gloves.
23. Disconnect the pigtail adapter from the inflator module as soon as possible.
24. Dispose of the deployed inflator module through normal refuse channels.
25. Wash hands with a mild soap.

Deployment Inside Vehicle-Vehicle Scrapping Procedures

Deploy inflator modules inside of the vehicle when destroying the vehicle or when salvaging the vehicle for parts. This includes but is not limited to the following situations:

- The vehicle has completed its useful life.
- Irreparable damage occurs to the vehicle in a non-deployment type accident.
- Irreparable damage occurs to the vehicle during a theft.
- The vehicle is being salvaged for parts to be used on a vehicle with a different VIN as opposed to rebuilding as the same VIN.

CAUTION: Refer to SIR Inflatable Module Deployment Outside Vehicle Caution in Cautions and Notices.

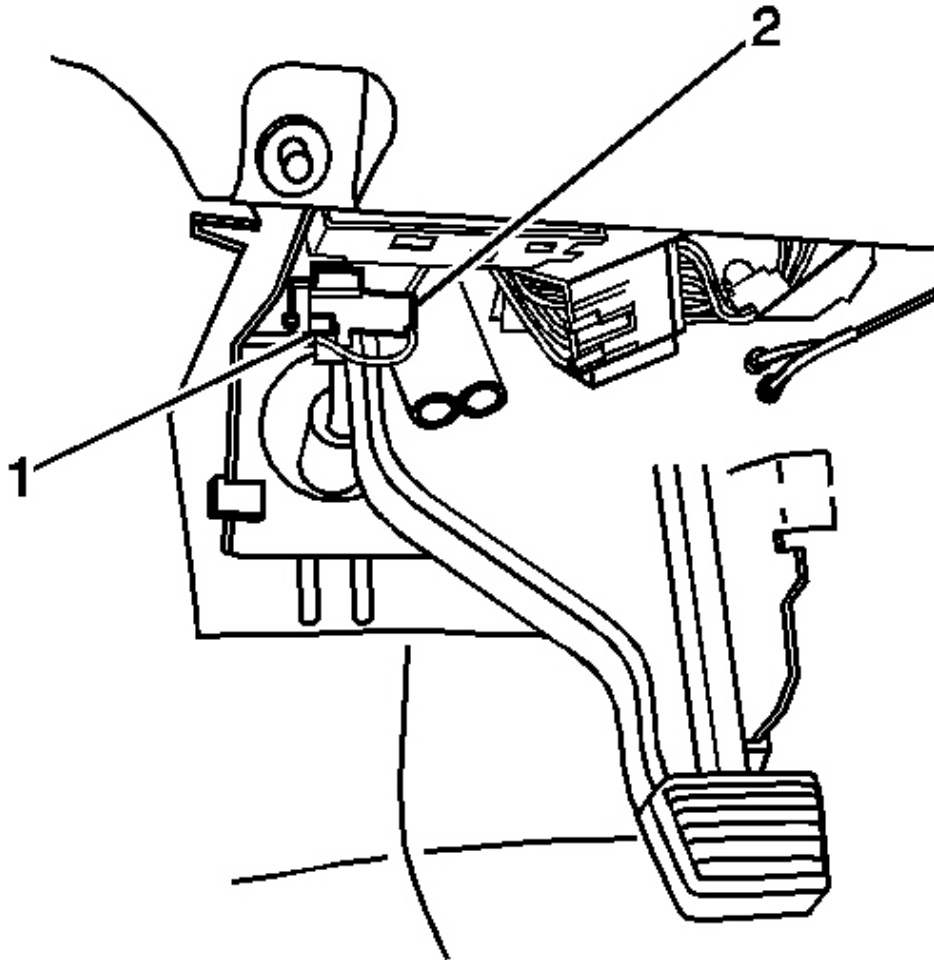

Fig. 70: Connector Position Assurance (CPA) & Steering Wheel Module Yellow 4-Way Connector - Zone 7
Courtesy of GENERAL MOTORS CORP.

1. Turn OFF the ignition.
2. Remove the ignition key.
3. Put on safety glasses.
4. Remove all loose objects from the front seats.
5. Disconnect the inflatable restraint steering wheel module connector (2) located next to the steering

column.

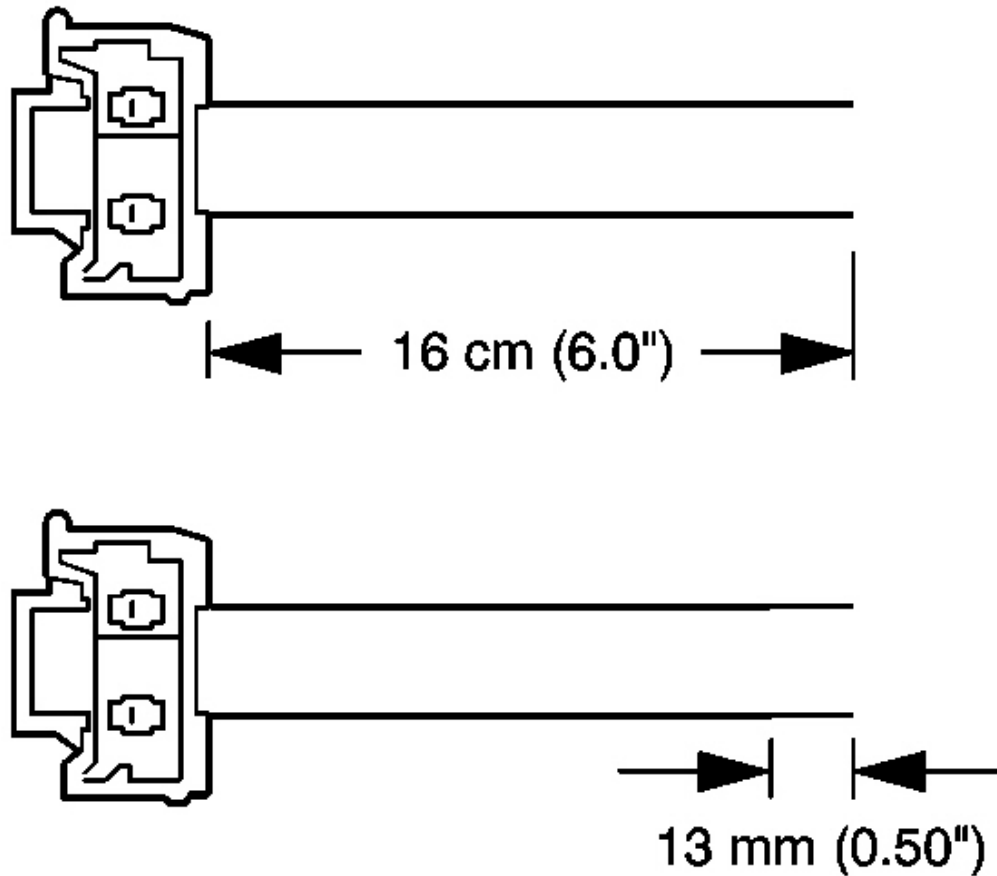

Fig. 71: Measuring Connector Wires
Courtesy of GENERAL MOTORS CORP.

6. Cut the steering wheel module harness connector out of the vehicle, leaving at least 16 cm (6 in) of wire at the connector.
7. Strip 13 mm (0.5 in) of insulation from each of the connector wire leads.

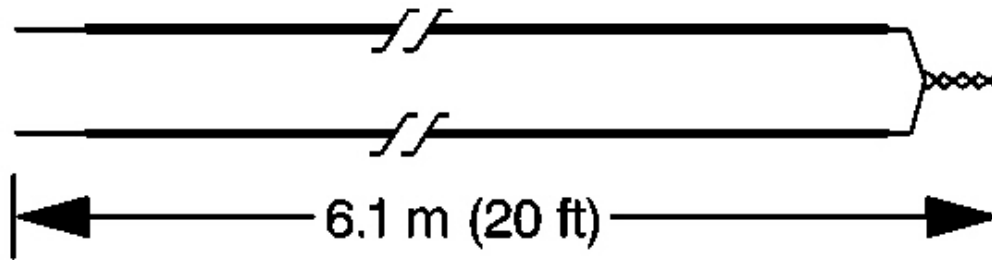

Fig. 72: Fabricating 20 Ft. Deployment Harness
 Courtesy of GENERAL MOTORS CORP.

8. Cut two 6.1 m (20 ft) deployment wires from a 0.8 mm (18 gauge) or thicker multi-strand wire. Use these wires to fabricate the deployment harness.
9. Strip 13 mm (0.5 in) of insulation from both ends of the wires cut in the previous step.
10. Twist together one end from each of the wires in order to short the wires. Deployment wires shall remain shorted, and not connected to a power source until you are ready to deploy the inflator module.

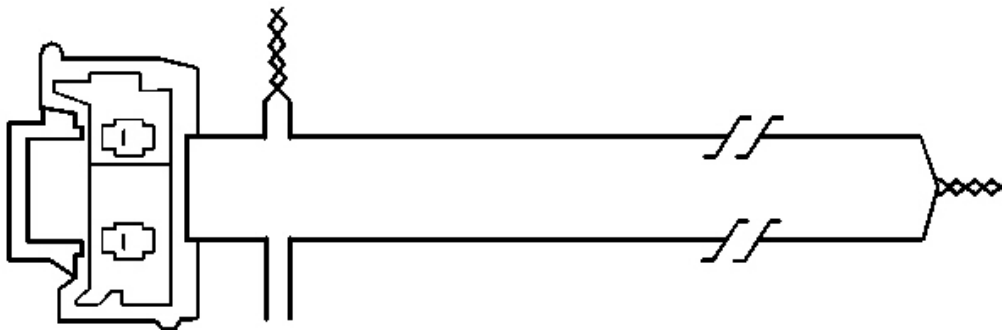

Fig. 73: View Of Twisted Connector Wire To Deployment Wire
 Courtesy of GENERAL MOTORS CORP.

11. Twist together one connector wire lead to one deployment wire.
12. Inspect that the connection is secure.

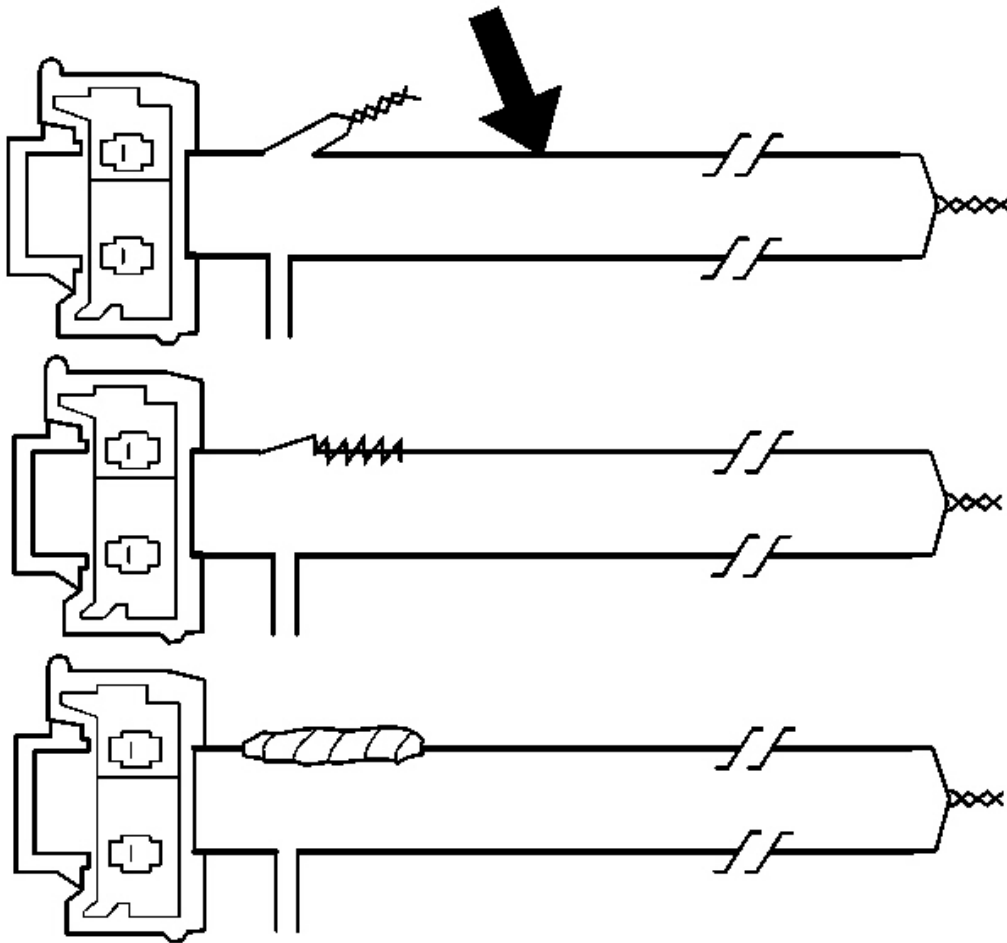

Fig. 74: Identifying Twisted Connection
Courtesy of GENERAL MOTORS CORP.

13. Bend flat the twisted connection.
14. Secure and insulate the connection using electrical tape.

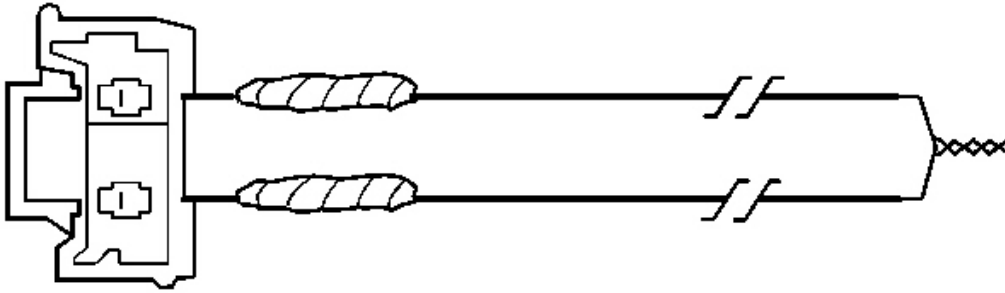

Fig. 75: View Of Insulated Connector Wire To Deployment Wire
Courtesy of GENERAL MOTORS CORP.

15. Twist together, bend, and tape the remaining connector wire lead to the remaining deployment wire.
16. Inspect that the connection is secure.

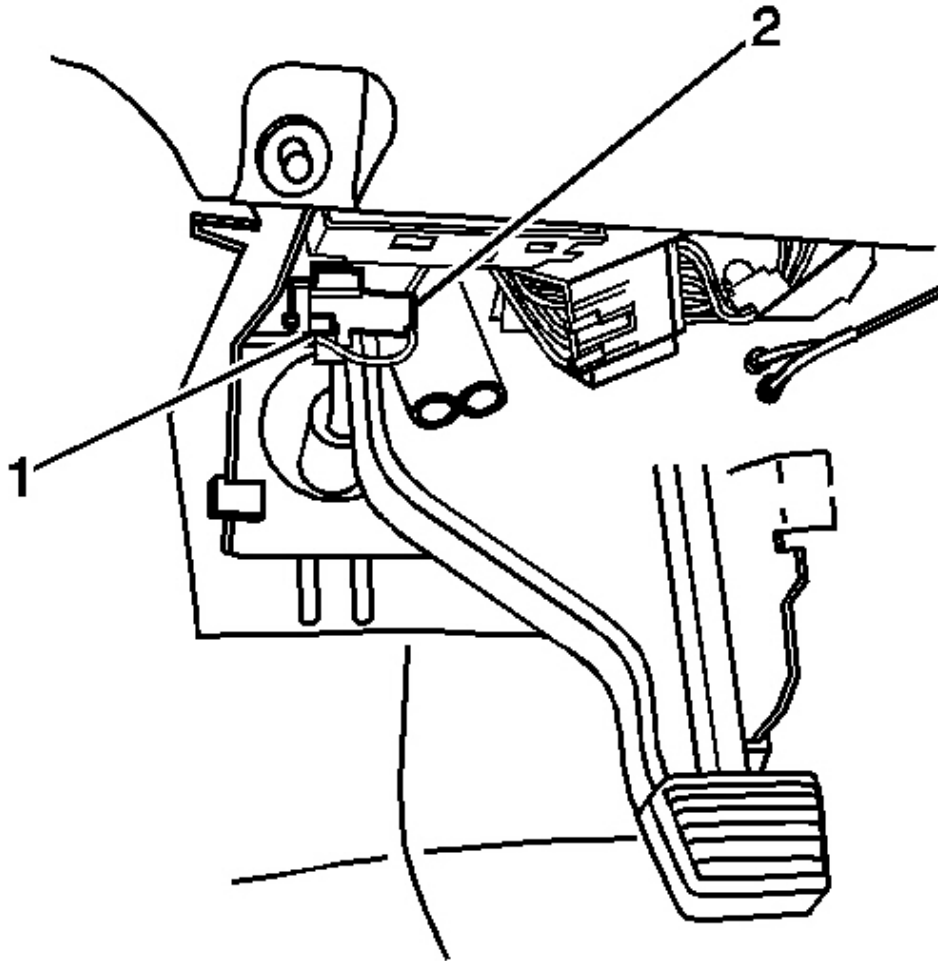

Fig. 76: Connector Position Assurance (CPA) & Steering Wheel Module Yellow 4-Way Connector - Zone 7
Courtesy of GENERAL MOTORS CORP.

17. Connect the deployment harness to the steering wheel module connector.
18. Route the deployment harness out of the vehicle's driver side.

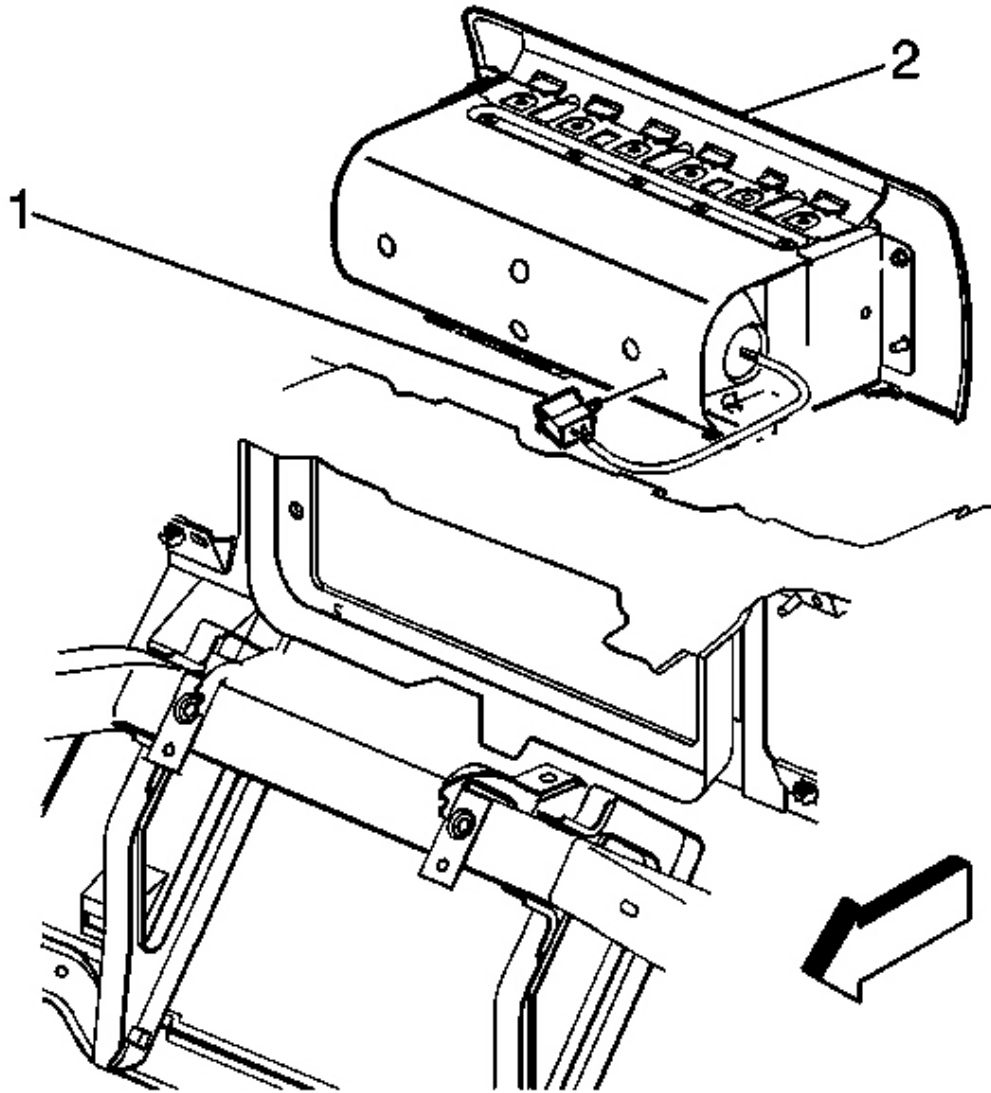

Fig. 77: Connector Position Assurance (CPA) & I/P Module Yellow 4-Way Connector - Zone 5
Courtesy of GENERAL MOTORS CORP.

19. Disconnect the inflatable restraint I/P module connector (1) located behind the I/P module (2).

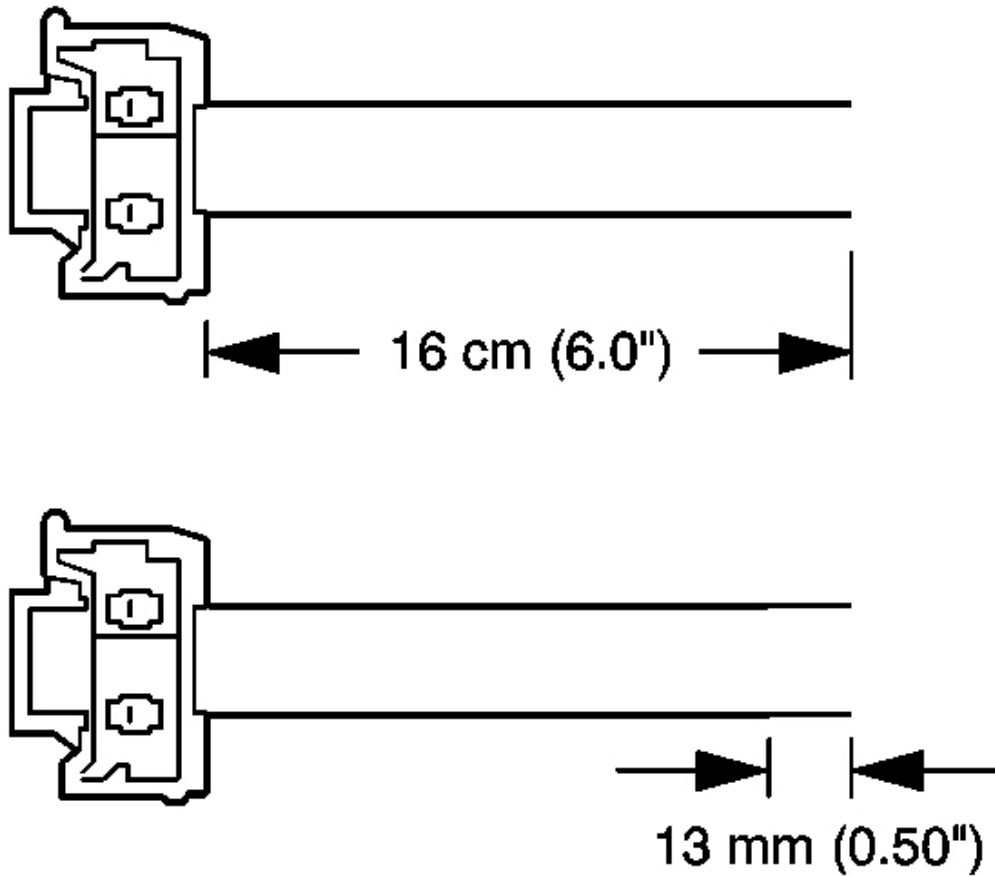

Fig. 78: Measuring Connector Wires
Courtesy of GENERAL MOTORS CORP.

20. Cut the I/P module harness connector out of the vehicle, leaving at least 16 cm (6 in) of wire at the connector.
21. Strip 13 mm (0.5 in) of insulation from each of the connector wire leads.

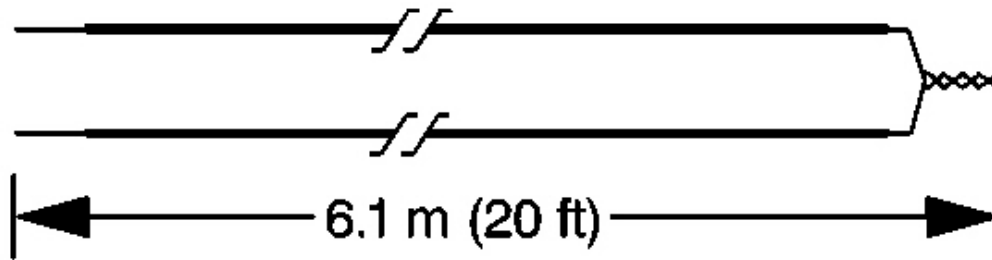

Fig. 79: Fabricating 20 Ft. Deployment Harness
 Courtesy of GENERAL MOTORS CORP.

22. Cut two 6.1 m (20 ft) deployment wires from a 0.8 mm (18 gauge) or thicker multi-strand wire. These wires will be used to fabricate the deployment harness.
23. Strip 13 mm (0.5 in) of insulation from both ends of the wires cut in the previous step.
24. Twist together one end from each of the wires in order to short the wires.

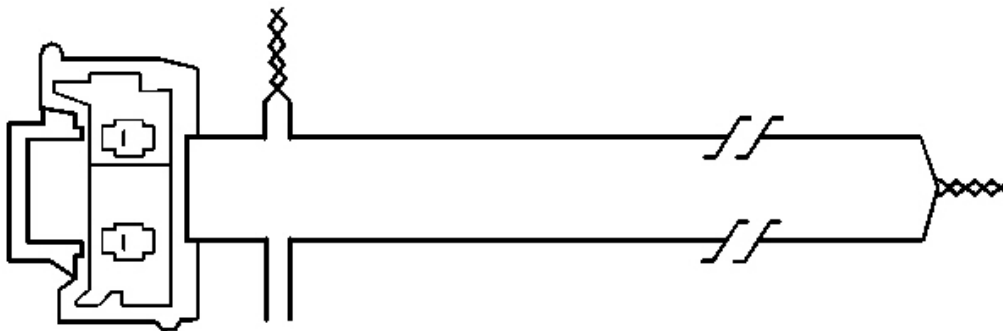

Fig. 80: View Of Twisted Connector Wire To Deployment Wire
 Courtesy of GENERAL MOTORS CORP.

25. Twist together one connector wire lead to one deployment wire.
26. Inspect that the connection is secure.

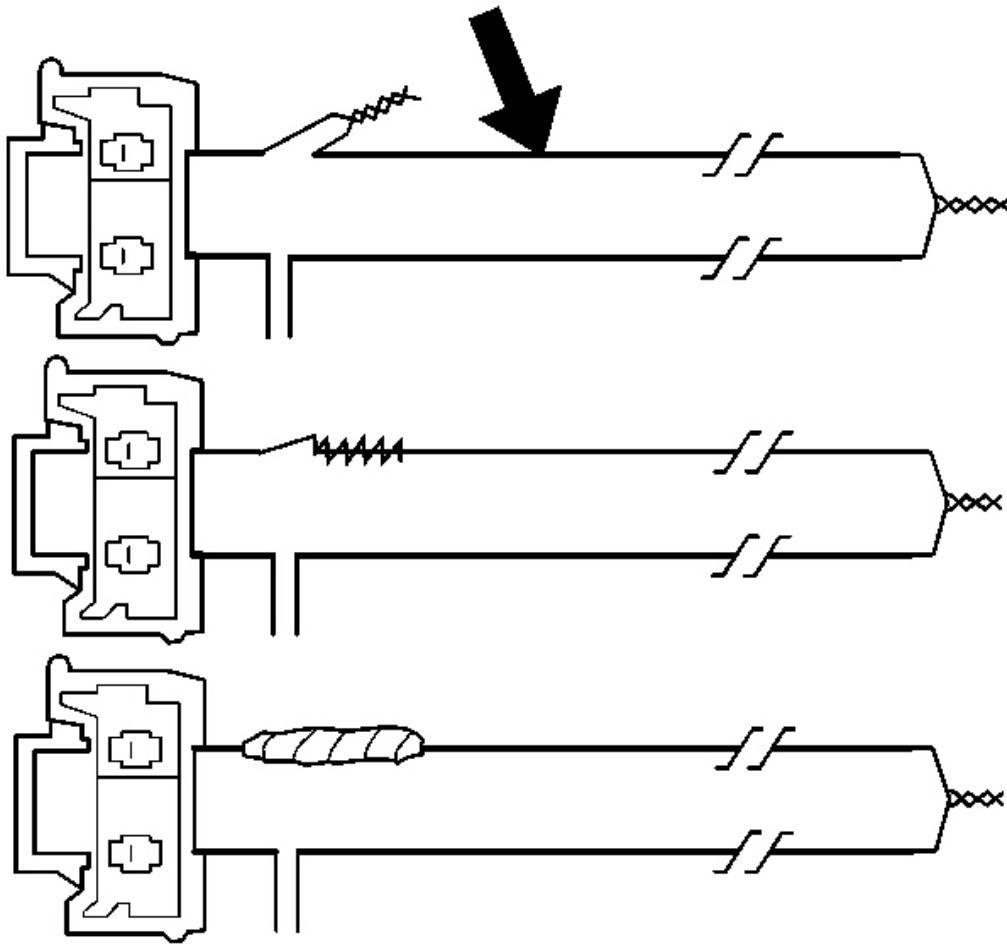

Fig. 81: Identifying Twisted Connection
Courtesy of GENERAL MOTORS CORP.

27. Bend flat the twisted connection.
28. Secure and insulate the connection using electrical tape.

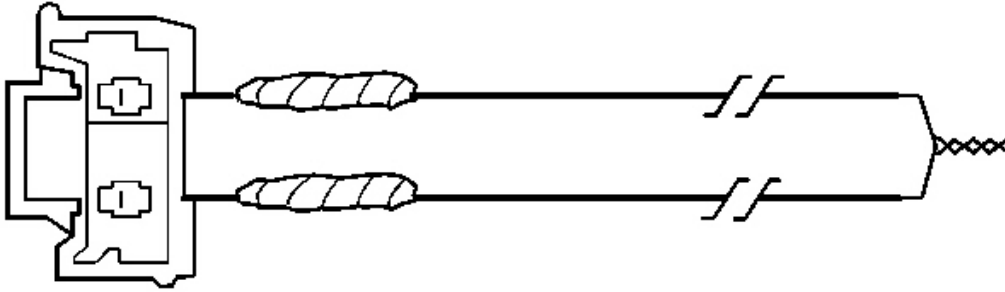

Fig. 82: View Of Insulated Connector Wire To Deployment Wire
Courtesy of GENERAL MOTORS CORP.

29. Twist together, bend, and tape the remaining connector wire lead to the remaining deployment wire.
30. Inspect that the connection is secure.

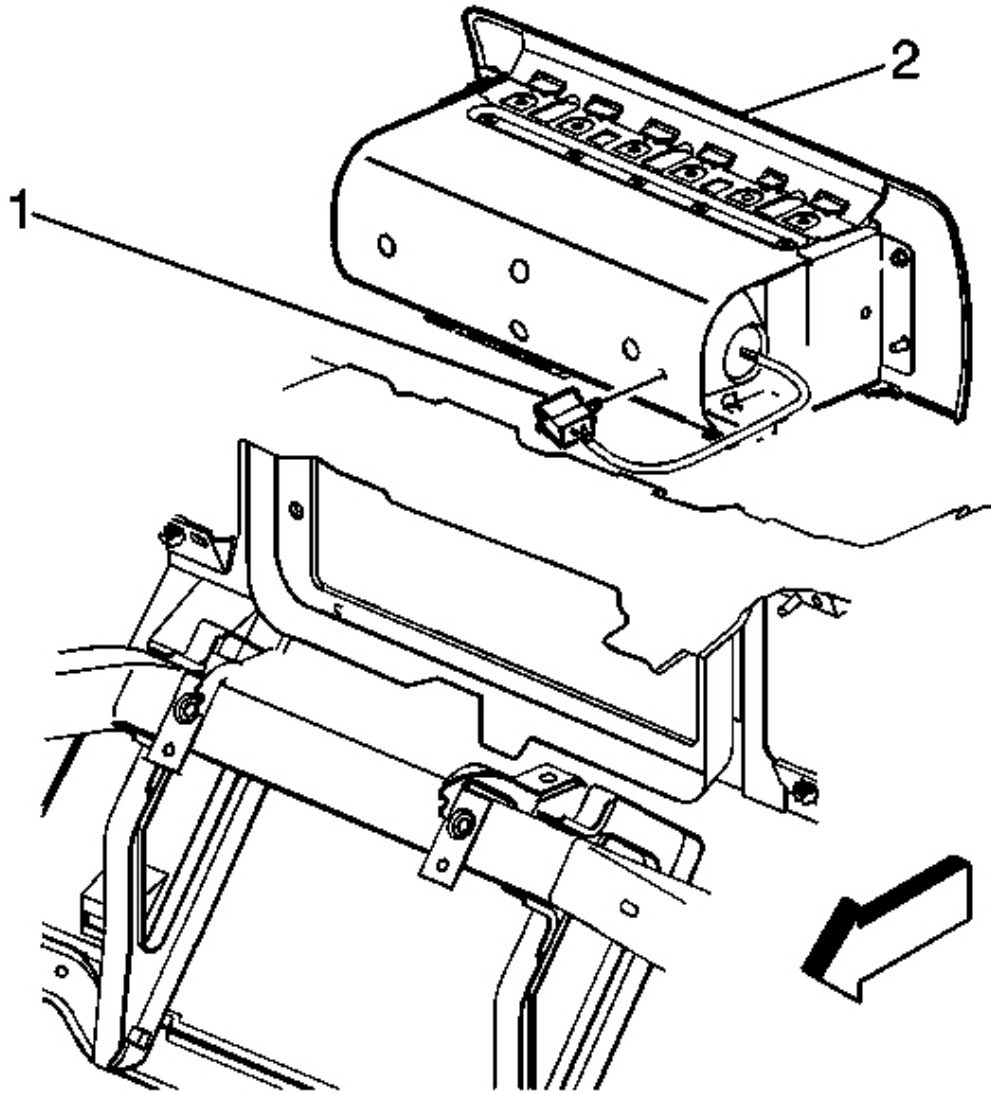

Fig. 83: Connector Position Assurance (CPA) & I/P Module Yellow 4-Way Connector - Zone 5
Courtesy of GENERAL MOTORS CORP.

31. Connect the deployment harness to the I/P module connector (1).
32. Route the deployment harness out of the vehicle's passenger side.
33. Stretch out all of the deployment harness wires on the left and right side of the vehicle to their full length.
34. Completely cover the windshield and front door window openings with a drop cloth.
35. Place a power source, 12 V minimum/2 A minimum, i.e., a vehicle battery, near the shorted ends of the

deployment harnesses.

IMPORTANT: The inflator module will deploy when the wire ends contact the power source.

36. Separate one set of wires and touch the wire ends to the power source in order to deploy the inflator modules.
37. Disconnect the deployment harness from the power source and twist the wire ends together.
38. Continue the same process with the remaining deployment harnesses that are available.
39. Remove the drop cloth from the vehicle.
40. Disconnect all harnesses from the vehicle.
41. Discard the harnesses.
42. Scrap the vehicle in the same manner as a non-SIR equipped vehicle.
43. If one or more of the inflator modules did not deploy, perform the following steps to remove the undeployed modules from the vehicle:
 - If the steering wheel module did not deploy, refer to **Inflatable Restraint Steering Wheel Module Replacement** .
 - If the IP module did not deploy, refer to **Inflatable Restraint Instrument Panel Module Replacement** .
44. Call the Technical Assistance Group for further assistance.

DESCRIPTION AND OPERATION

SIR SYSTEM DESCRIPTION AND OPERATION

SIR System Overview

The supplemental inflatable restraint (SIR) system supplements the protection offered by the occupant's seat belt system (2). The SIR system may contain several inflator modules located throughout the vehicle, i.e. steering wheel module (1) and instrument panel (I/P) module (1). Each inflator module has a deployment loop that is controlled by the sensing and diagnostic module (SDM) mounted inside the vehicle. The SDM determines the severity of a collision with the assistance of various sensor inputs. When the SDM detects a collision of sufficient force it will process the information provided by the sensors to further support air bag deployment. The SDM performs continuous diagnostic monitoring of the SIR system electrical components. Upon detection of a circuit malfunction, the SDM will set a DTC and inform the driver by turning the AIR BAG indicator ON. The steering column (1) and knee bolsters (3) are designed to absorb energy and compress during frontal collisions in order to limit leg movement and decrease the chance of injury to the driver and passenger.

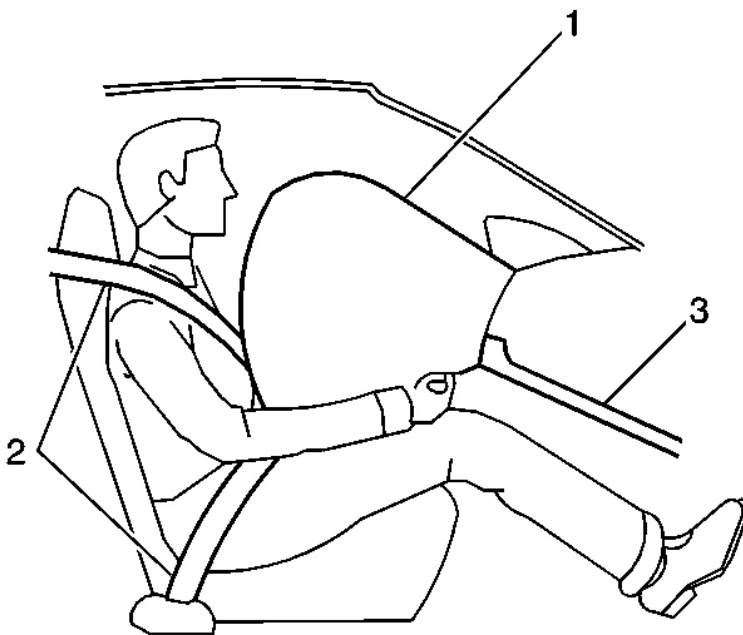
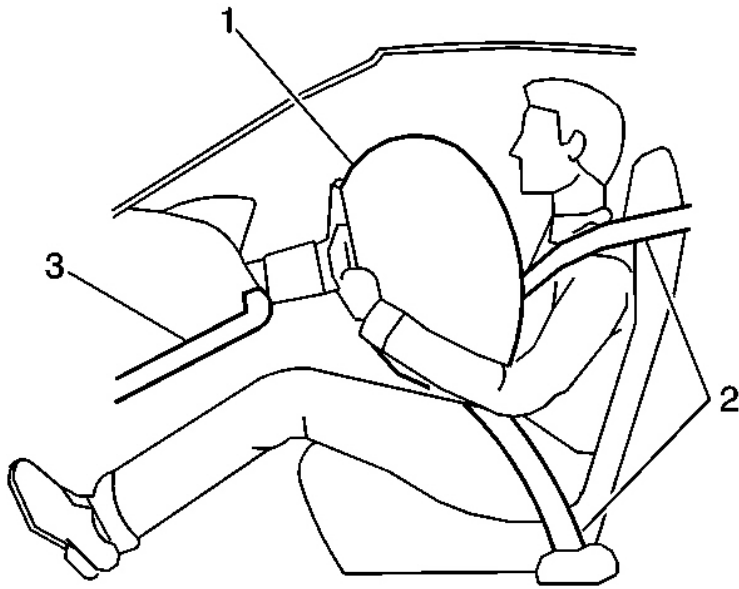

Fig. 84: Deployed Inflatable Restraint
Courtesy of GENERAL MOTORS CORP.

Frontal SIR System Description

The frontal SIR system consists of the following components:

- AIR BAG indicator located in the instrument panel cluster (IPC)
- Driver and passenger knee bolsters
- Inflatable restraint electronic frontal sensors (EFS) (left/right)
- Inflatable restraint I/P module.
- Inflatable restraint I/P module disable switch
- Inflatable restraint I/P module disable switch indicator
- Inflatable restraint sensing and diagnostic module (SDM)
- Inflatable restraint steering wheel module
- Inflatable restraint steering wheel module coil
- Inflatable restraint wiring harnesses
- Steering wheel and column

A frontal collision of sufficient force will deploy the frontal air bags. The SDM contains a sensing device that converts vehicle velocity changes to an electrical signal. In the event of a frontal collision, the SDM receives a signal from the electronic frontal sensors which assists the SDM in determining the severity of some frontal collisions. The SDM contains a microprocessor that performs calculations using the measured accelerations. The SDM compares these calculations to a value stored in memory. When the generated calculations exceed the stored value, the SDM will cause current to flow through the frontal deployment loops deploying the frontal air bags. Once the air bags are inflated they quickly deflate through the air bag vent holes. After the air bags have deployed, the SDM sets a diagnostic trouble code (DTC) and requests the instrument panel cluster (IPC) to turn the AIR BAG indicator ON. The SDM, I/P module, steering wheel module, steering wheel module coil and the connecting wires make up the frontal deployment loops. The SDM continuously monitors the deployment loops for malfunctions and turns the AIR BAG indicator ON if a fault is detected.

Inflatable Restraint Sensing and Diagnostic Module (SDM)

The sensing and diagnostic module (SDM) is a microprocessor and the control center for the SIR system. The SDM contains internal sensors along with several external sensors, if equipped, mounted at various locations on the vehicle. In the event of a collision, the SDM performs calculations using the signals received from the internal and external sensors. The SDM compares the results of the calculations to values stored in memory. When these calculations exceed the stored value, the SDM will cause current to flow through the appropriate deployment loops to deploy the air bags. The SDM records the SIR system status when a deployment occurs and requests the instrument panel cluster (IPC) to turn the AIR BAG indicator ON. The SDM performs continuous diagnostic monitoring of the SIR system electrical components and circuitry when the ignition is turned ON. If the SDM detects a malfunction, a DTC will be stored and the SDM will command the AIR BAG indicator ON. In the event that ignition 1 voltage is lost during a collision, the SDM maintains a 23-volt loop reserve (23 VLR) for deployment of the air bags. It is important to note, when disabling the SIR system for servicing or rescue operations to allow the 23 VLR to dissipate, which could take up to 1 minute.

AIR BAG Indicator

The AIR BAG indicator, located in the IPC is used to notify the driver of SIR system malfunctions and to verify that the SDM is communicating with the IPC. When the ignition is turned ON, the SDM is supplied with

ignition 1 voltage and requests the IPC to flash the AIR BAG indicator 7 times. While flashing the indicator, the SDM conducts test on all SIR system components and circuits. If no malfunctions are detected the SDM will communicate with the IPC through the class 2 serial data circuit and request the IPC to turn the AIR BAG indicator OFF. The SDM provides continuous monitoring of the air bag circuits by conducting a sequence of checks. If a malfunction is detected the SDM will store a diagnostic trouble code (DTC) and request the IPC to turn the AIR BAG indicator ON. The presence of a SIR system malfunction could result in non-deployment of the air bags. The AIR BAG indicator will remain ON until the malfunction has been repaired.

Inflator Modules

The inflator modules contain a housing, inflatable air bag, an initiating device, canister of gas generating material and, in some cases, stored compressed gas. The initiator is part of the inflator module deployment loop. When the vehicle is involved in a collision of sufficient force, the SDM will cause current to flow through the deployment loops to the initiator. Current passing through the initiator ignites the material in the canister producing a rapid generation of gas and the release of compressed gas, if present. The gas produced from this reaction rapidly inflates the air bag. Once the air bag is inflated it quickly deflates through the air bag vent holes and/or the bag fabric.

Each inflator module is equipped with a shorting bar located on the connector of the module. The shorting bar shorts the inflator module deployment loop circuitry to prevent unwanted deployment of the air bag when servicing the inflator module.

Inflatable Restraint Steering Wheel Module Coil

The steering wheel module coil is attached to the steering column and is located under the steering wheel. The steering wheel module coil consists of two or more current-carrying coils. The coils allow the rotation of the steering wheel while maintaining continuous electrical contact between the driver deployment loop and the steering wheel module. Four coil wires are used for the steering wheel module deployment loop. Additional coil wires are used for accessories attached to the steering wheel depending on the vehicle model. The steering wheel module coil connector is located near the base of the steering column. The connector contains a shorting bar that shorts the steering wheel module coil deployment loop circuitry to prevent unwanted deployment of the air bag when it is disconnected.

Inflatable Restraint Electronic Frontal Sensor (EFS)

The electronic frontal sensors (EFS) are equipped on vehicles to supplement the SIR system performance. The EFS is an electronic sensor and is not part of the deployment loops, but instead provides an input to the SDM. The EFS can assist in determining the severity of some frontal collisions. The SDM uses the input from the discriminating sensor to assist in determining the severity of a frontal collision further supporting air bag deployment. If the SDM determines a deployment is warranted, the SDM will cause current to flow through the deployment loops deploying the frontal air bags.

Inflatable Restraint I/P Module Disable Switch

The instrument panel (I/P) module disable switch is a manual 2-position key switch located inside the vehicle. The I/P module disable switch allows the vehicle operator the ability to enable or disable the I/P module (passenger frontal air bag). The vehicle operator must disable the I/P module if a rear-facing child seat is installed in the front passenger seat. The I/P module disable switch interfaces with the sensing and diagnostic

module (SDM) to request the enabling or disabling of the I/P module. The occupants are notified of the enabling or disabling of the I/P module via the I/P module disable switch ON/OFF indicator located in the I/P module disable switch.

Inflatable Restraint I/P Module Disable Switch Indicator

The instrument panel (I/P) module disable switch ON/OFF indicator is an LED located in a position that can be viewed by the occupants in the front seats. The location varies depending on the vehicle. When the I/P module disable switch is in the disable position, the I/P module disable switch indicator illuminates. When the I/P module disable switch is in the enable position, the I/P module disable switch indicator is not illuminated. The I/P module disable switch indicator will dim to a lower intensity when the headlamp switch is turned ON.

Inflatable Restraint Wiring Harnesses

The inflatable restraint wiring harnesses connect the sensing and diagnostic module (SDM), inflator modules, passenger presence system (PPS), electronic frontal sensors (EFS), seat position switches (SPS), passenger seat belt tension retractor sensor, and the class 2 serial data circuit together using weather pack connectors. SIR deployment loop connectors are yellow in color for easy identification. When repairing SIR system wiring harnesses, follow the proper testing and wiring repair procedures outlined in this manual.

Steering Wheel and Column

The steering wheel and column are designed to absorb energy when driver contact is made with the steering wheel or inflated air bag. In a frontal collision the driver may contact the steering wheel directly or load the steering wheel and column through the inflated air bag. When the driver applies load to the air bag or steering wheel the column will compress downward absorbing some of the impact, helping to reduce bodily injuries to the driver. The steering wheel and column must be inspected for damage after a collision.

Driver and Passenger Knee Bolsters

The knee bolsters are designed to help restrain the lower torsos of front seat occupants by absorbing energy through the front seat occupants' upper legs. In a frontal collision the front seat occupants legs may come in contact with the knee bolsters. The knee bolsters are designed to crush or deform absorbing some of the impact, which helps to reduce bodily injuries. The driver and passenger knee bolsters are located in the lower part of the instrument panel and must be inspected for damage after a collision.

SPECIAL TOOLS AND EQUIPMENT

SPECIAL TOOLS

Special Tools

Illustration	Tool Number/Description

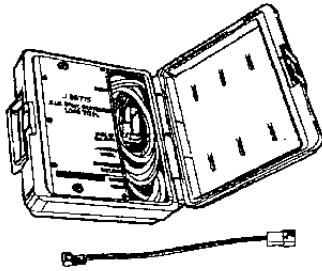

J 38715-A
SIR Driver/Passenger Load Tool



J 38826
SIR Deployment Harness

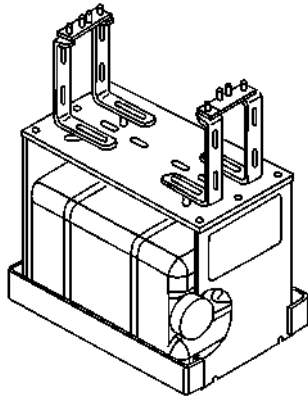

J 39401-B
SIR Deployment Fixture